

1

Complete each of the following sentences, **A**, **B**, **C**, **D** and **E**, by choosing the correct ending from **K**, **L**, **M**, **N** or **O**.

The first one has been done for you.

- A The current through a resistor depends .....  O
- B A direct current .....
- C In a series circuit, the potential difference .....
- D An alternating current .....
- E In a parallel circuit, the potential difference .....

**K** ..... across each component is the same.

**L** ..... is supplied by a cell or battery.

**M** ..... is constantly changing direction.

**N** ..... of the power supply is shared by the components.

**O** ..... on the potential difference across the resistor.

**(Total 3 marks)**

2

(a) The diagram shows the circuit used by a student to measure the power of a filament lamp.

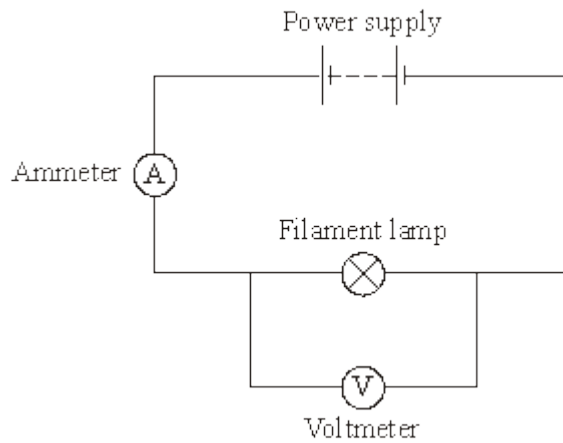

Name a component connected in parallel with the filament lamp.

.....

(1)

(b) By adding another component to the circuit, the student is able to obtain a range of ammeter and voltmeter readings.

Ammeter reading in amps	Voltmeter reading in volts
0.10	1.0
0.15	2.0
0.20	4.0
0.25	7.0
0.30	11.0

(i) Which **one** of the following components did the student add to the circuit?

Draw a ring around your answer.

**fuse**                      **switch**                      **variable resistor**

(1)

(ii) What is the range of ammeter readings taken by the student?

from ..... amps to ..... amps

(1)

- (iii) Use the data in the table and the equation in the box to calculate the **maximum** power of the filament lamp.

$$\frac{\text{power}}{\text{(watt, W)}} = \frac{\text{current}}{\text{(ampere, A)}} \times \frac{\text{potential difference}}{\text{(volt, V)}}$$

Show clearly how you work out your answer.

.....  
 .....

Power = ..... W

(3)

- (c) Complete the following sentence by drawing a ring around the correct line in the box.

As the temperature of a filament lamp increases, its resistance

increases
remains constant
decreases

(1)

(Total 7 marks)

**3**

The diagram shows a simple type of car rear window heater. The six heating elements are exactly the same.

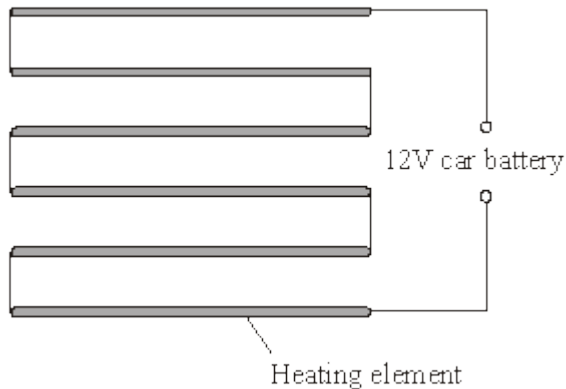

Each heating element has a resistance of  $5 \Omega$ . The current passing through each element is  $0.4$

A.

- (i) Calculate the total resistance of the six heating elements.

Show clearly how you work out your answer.

.....  
.....

Total resistance = ..... ohms

**(2)**

- (ii) Why is the current passing through each element the same?

.....  
.....

**(1)**

- (iii) What is the total current passing through the whole circuit?

.....

**(1)**

- (iv) How is the 12 volt potential difference of the car battery shared between the six heating elements?

.....  
.....

**(1)**

**(Total 5 marks)**

4

- (a) The graphs, **A**, **B** and **C**, show how the current through a component varies with the potential difference (p.d.) across the component.

Draw a line to link each graph to the correct component.  
Draw only **three** lines.

### Component

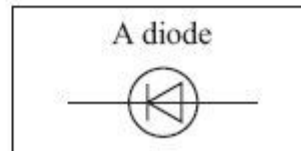
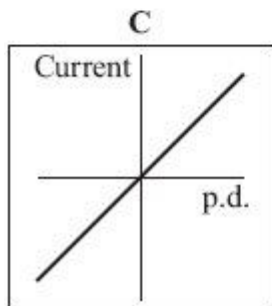
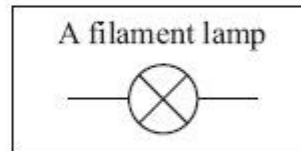
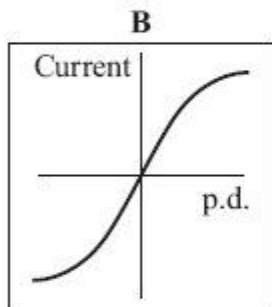
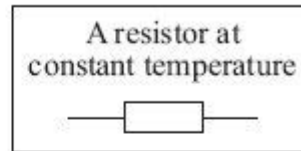
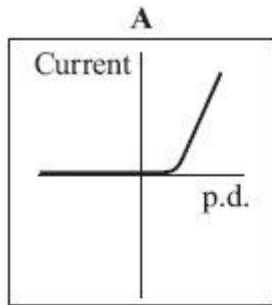

(2)

(b) Each of the circuits, **J**, **K** and **L**, include two diodes.

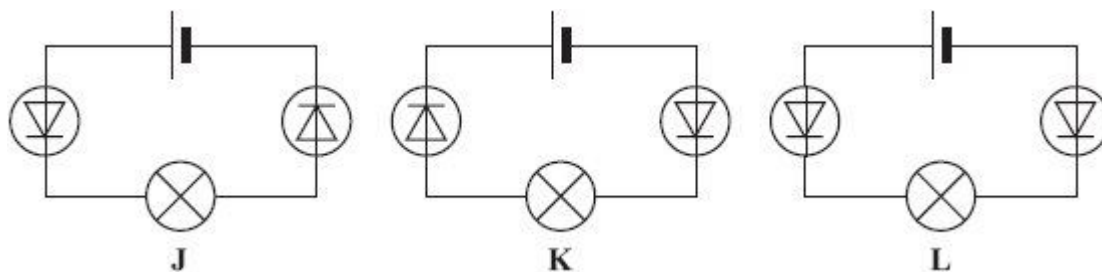

In which **one** of the circuits, **J**, **K** or **L**, would the filament lamp be on?

.....

(1)  
(Total 3 marks)

5

A circuit was set up as shown in the diagram.

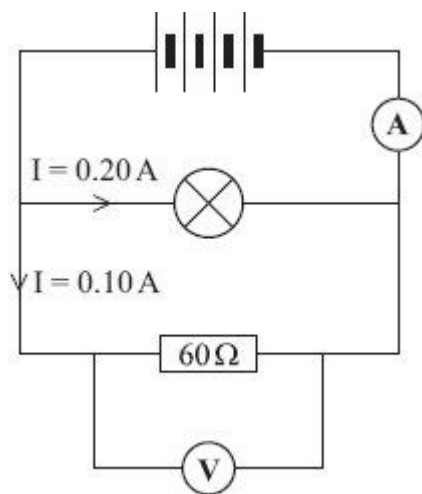

(a) Each cell provides a potential difference of 1.5 volts.

(i) What is the total potential difference provided by the four cells in the circuit?

.....

Total potential difference = ..... volts

(1)

(ii) What will be the reading on the voltmeter?

.....

(1)

- (b) The current through the lamp is 0.20 amps.  
The current through the resistor is 0.10 amps.

What is the reading on the ammeter?

.....

Reading on ammeter = ..... amps

(1)

- (c) Use a phrase from the box to complete the following sentence.

<b>greater than</b>	<b>equal to</b>	<b>smaller than</b>
---------------------	-----------------	---------------------

The resistance of the lamp is ..... 60  $\Omega$ .

Give a reason for your answer.

.....

.....

(2)

(Total 5 marks)

**6**

The diagram shows someone accidentally touching the live wire inside a dismantled 230 volt mains electricity socket.

A current flows through the person giving him an electric shock.

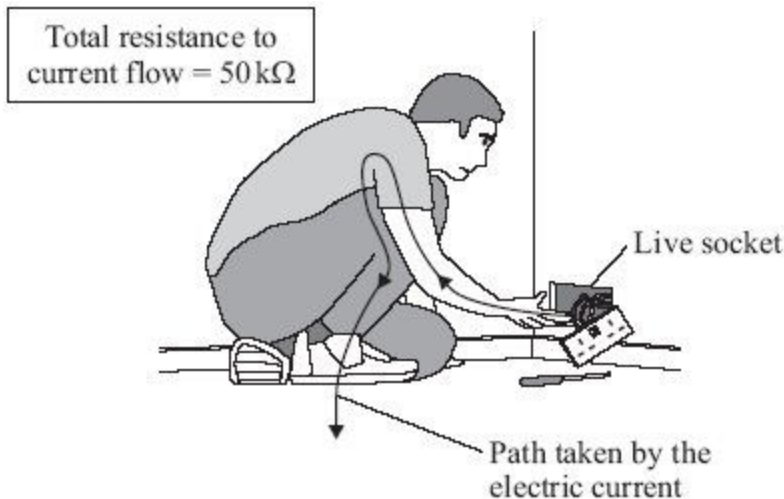

- (a) (i) Calculate the current that will flow through the person.

Show clearly how you work out your answer.

.....  
.....

Current = ..... A

(2)

- (ii) Rubber is a good insulator.

Explain why it is a good idea for electricians to wear rubber soled boots when working.

.....  
.....  
.....  
.....

(2)

- (b) If the current flowing through a person is too high, the person cannot let go of the electrical source.

Different people were tested to see whether the ability to let go of an electrical source depended on the frequency of the current.

The results of the test are shown in the graph.

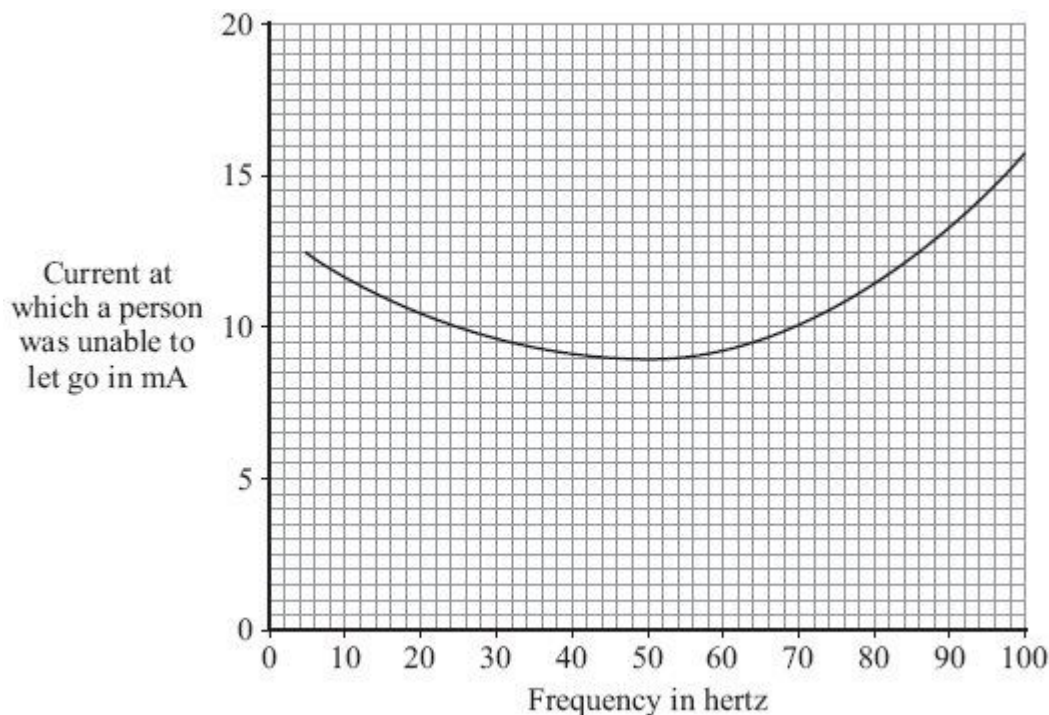



(i) What is the frequency of the mains electricity supply in the UK?

.....

(1)

(ii) From a safety point of view, is the frequency of the UK mains electricity supply suitable?

Give a reason for your answer.

.....  
.....

(1)

(c) The diagram shows how the electric supply cable is connected to an electric kettle. The earth wire is connected to the metal case of the kettle.

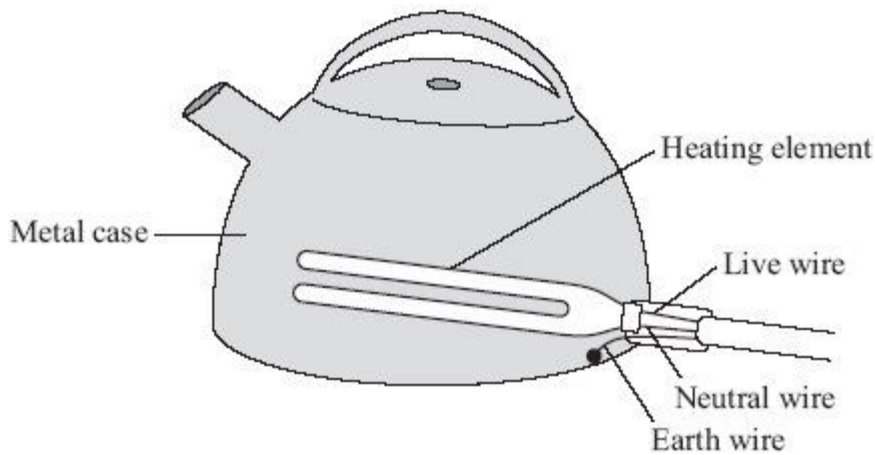

If a fault makes the metal case live, the earth wire and the fuse inside the plug protect anyone using the kettle from an electric shock.

Explain how.

.....  
.....  
.....  
.....

(2)  
(Total 8 marks)

7

- (a) The diagram shows the circuit used to investigate the resistance of a material. The diagram is incomplete; the ammeter and voltmeter are missing.

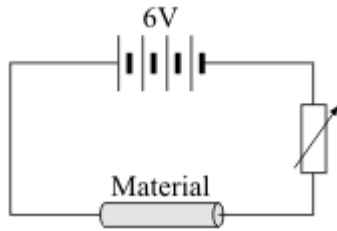

- (i) Draw the symbols for the ammeter and voltmeter on the diagram in the correct places. (2)
- (ii) How can the current through the material be changed?

.....  
 .....

(1)

- (b) The material, called conducting putty, is rolled into cylinders of different lengths but with equal thicknesses.

**Graph 1** shows how the resistance changes with length.

**Graph 1**

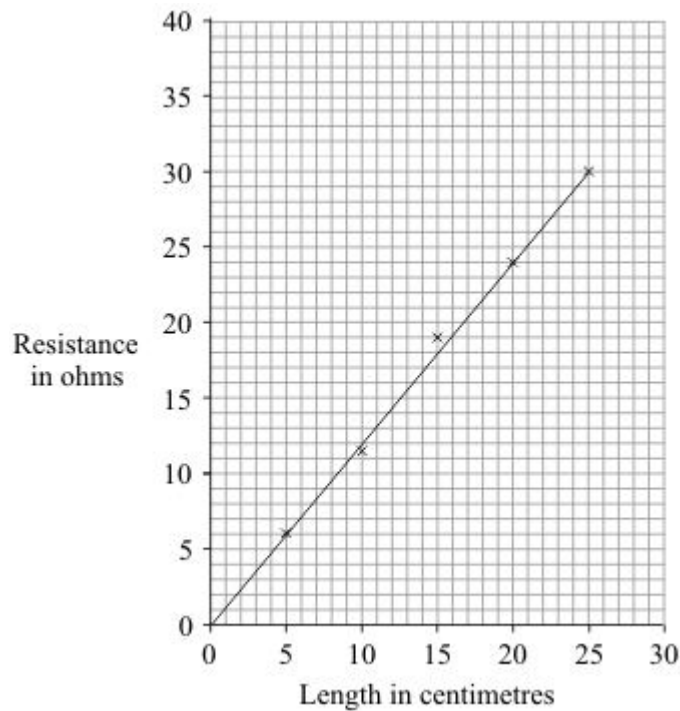

(i) Why has the data been shown as a line graph rather than a bar chart?

.....  
 .....

(1)

(ii) The current through a 30 cm length of conducting putty was 0.15 A.

Use **Graph 1** to find the resistance of a 30 cm length of conducting putty.

Resistance = ..... ohms

(1)

(iii) Use your answer to (b)(ii) to calculate the potential difference across a 30 cm length of conducting putty.

Show clearly how you work out your answer.

.....  
 .....

Potential difference = ..... volts

(2)

(c) A second set of data was obtained using thicker pieces of conducting putty. Both sets of results are shown in **Graph 2**.

**Graph 2**

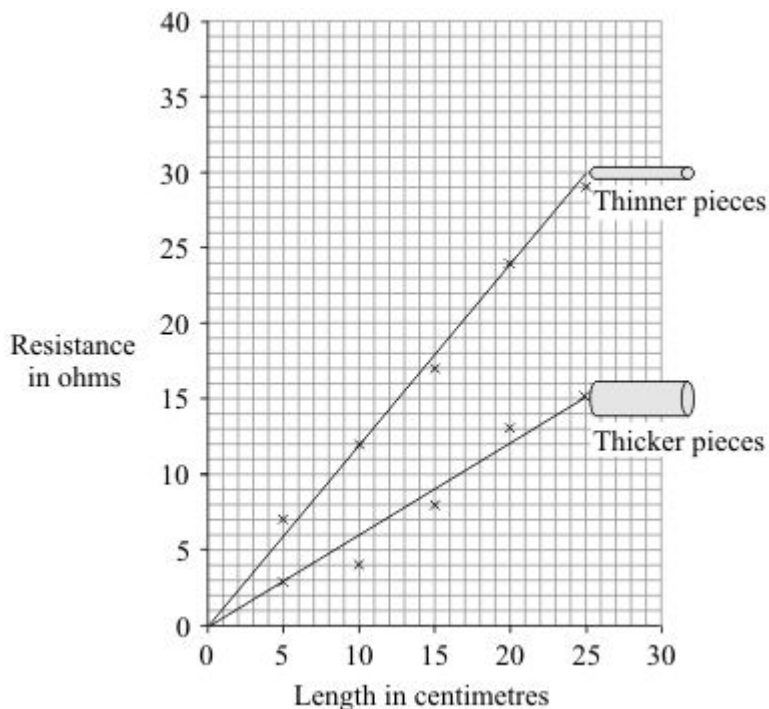

(i) What is the relationship between the resistance and the thickness of the conducting putty?

.....  
.....

(1)

(ii) Name **one** error that may have reduced the accuracy of the results.

.....

(1)

(iii) How could the reliability of the data have been improved?

.....  
.....

(1)

(Total 10 marks)

8

(a) The circuit diagram drawn below includes a component labelled **X**.

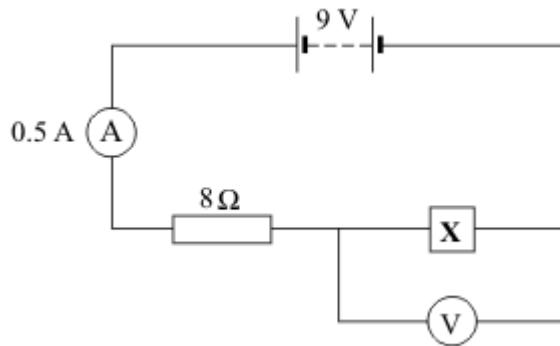

(i) Calculate the potential difference across the 8 ohm resistor.

Show clearly how you work out your answer.

.....  
.....

Potential difference = ..... volts

(2)

(ii) What is the potential difference across component **X**?

.....

(1)

(b) The graph shows how the resistance of component **X** changes with temperature.

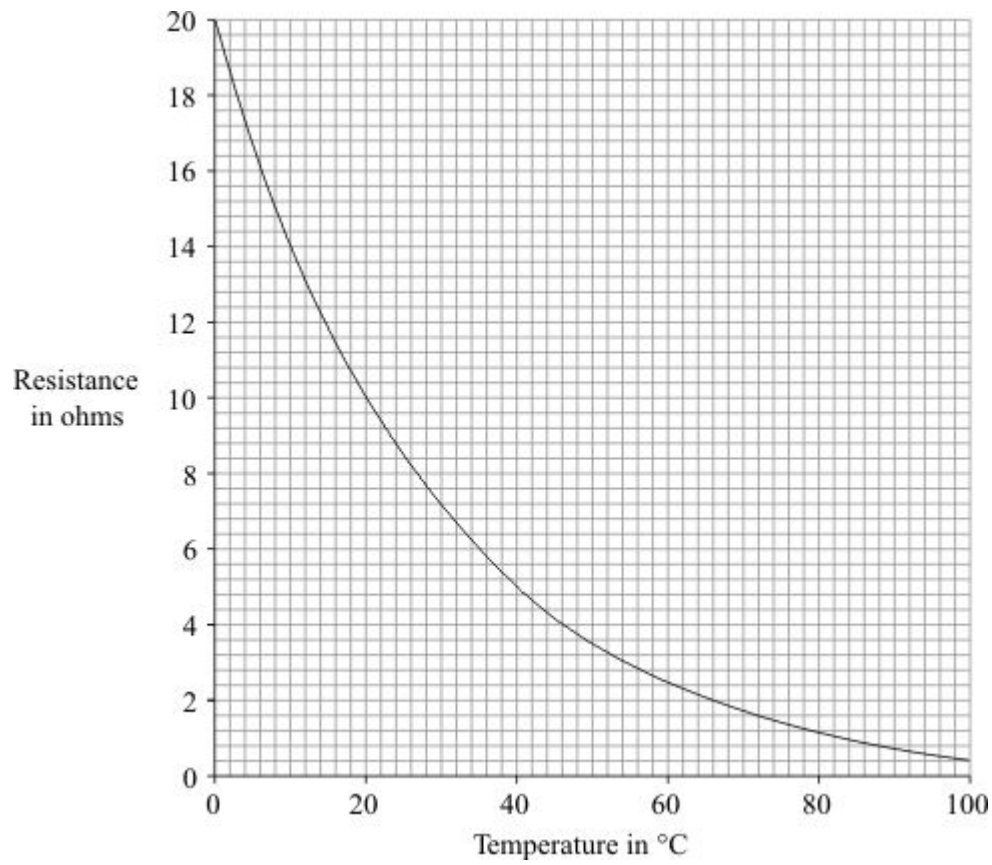

(i) What is component **X**?

.....

(1)

- (ii) Over which range of temperatures does the resistance of component **X** change the most?

Put a tick (✓) next to your choice.

0 °C to 20 °C

20 °C to 40 °C

40 °C to 60 °C

60 °C to 80 °C

80 °C to 100 °C

(1)  
(Total 5 marks)

9

The drawing shows three identical cells and two identical lamps joined in a circuit.

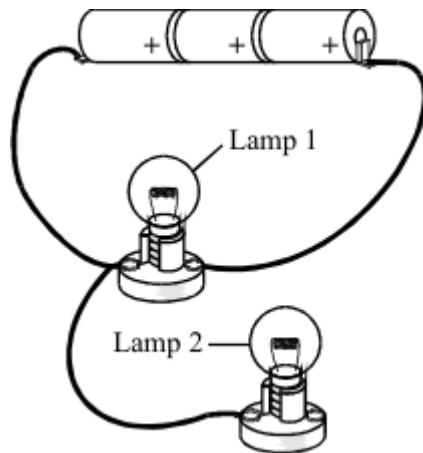

(a) Use the correct symbols to draw a circuit diagram for this circuit.

(3)

(b) Each of the cells provides a potential difference (voltage) of 1.5 volts. What is the total potential difference (voltage) provided by all three cells?

..... volts

(1)

(c) Complete this sentence by crossing out the **two** lines in the box that are wrong.

The current through lamp 2 will be 

smaller than
the same as
bigger than

 the current through lamp 1.

(1)

(Total 5 marks)

10

A set of Christmas tree lights is made from twenty identical lamps connected in series.



(a) Each lamp is designed to take a current of 0.25 A. The set plugs directly into the 230 V mains electricity supply.

(i) Write down the equation that links current, potential difference and resistance.

.....  
.....

(1)

- (ii) Calculate the resistance of **one** of the lamps. Show clearly how you work out your final answer and give the unit.

.....  
.....  
.....  
.....

Resistance = .....

**(4)**

- (iii) What is the total resistance of the set of lights?

.....  
.....

Total resistance = .....

**(1)**

- (b) How does the resistance of a filament lamp change as the temperature of the filament changes?

.....  
.....  
.....  
.....

**(1)**

**(Total 7 marks)**



11

The drawing shows the circuit used to investigate how the current through a 5 ohm ( $\Omega$ ) resistor changes as the potential difference (voltage) across the resistor changes.

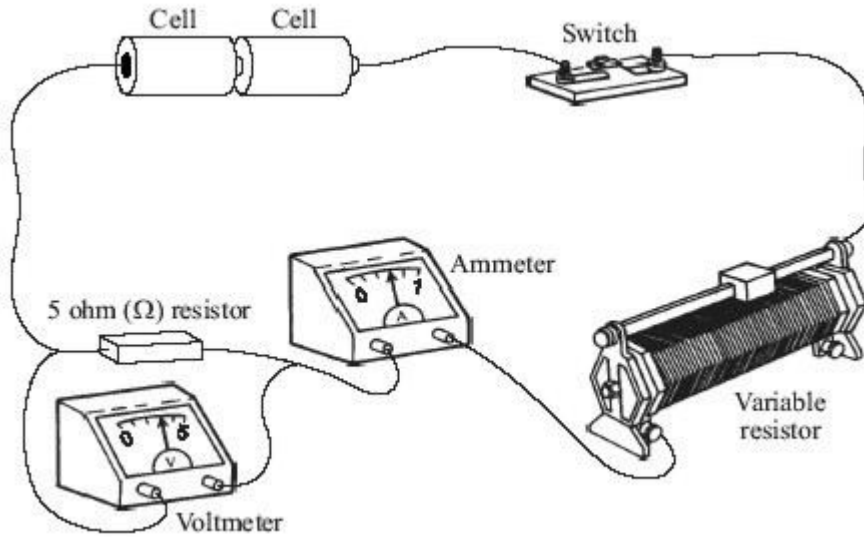

(a) Draw, in the space below, a circuit diagram of this circuit. Use the correct symbols for each part of the circuit.

(2)

(b) (i) Write down the equation that links current, potential difference and resistance.

.....

(1)

- (ii) Calculate the potential difference across the 5 ohm ( $\Omega$ ) resistor when the current through the resistor equals 0.4 A. Show clearly how you work out your final answer.

.....  
 .....

potential difference = ..... volts

(2)

- (iii) Complete the graph to show how the current through the resistor changes as the potential difference across the resistor increases from 0 V to 3 V. Assume the resistor stays at a constant temperature.

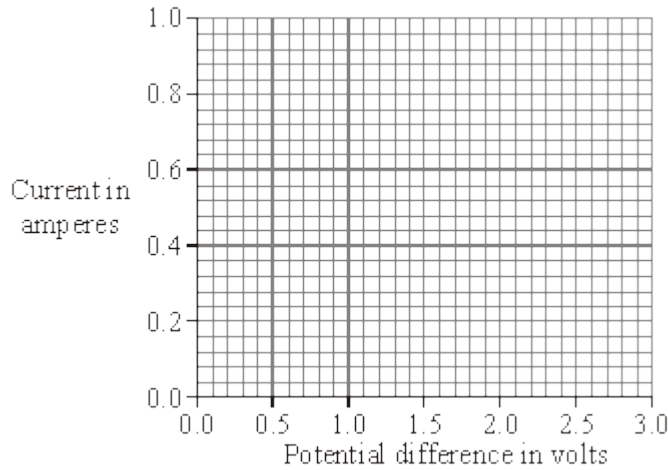

(2)

- (c) The resistor is replaced by a 3 V filament lamp. The resistance of the lamp increases as the potential difference across it increases. Why?

.....  
 .....

(1)

(Total 8 marks)

12

The diagram shows a 12 volt lighting system. Each lamp has a power of 32 watts.

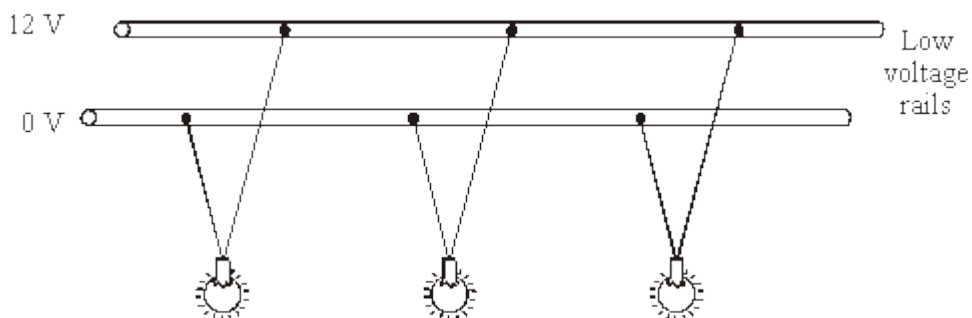

(i) Write down the equation that links current, potential difference and power.

.....

(1)

(ii) Calculate the input current to the lighting system. Show clearly how you work out your answer.

.....

.....

current = ..... A

(2)

(Total 3 marks)

13

The circuit shown has four identical ammeters.

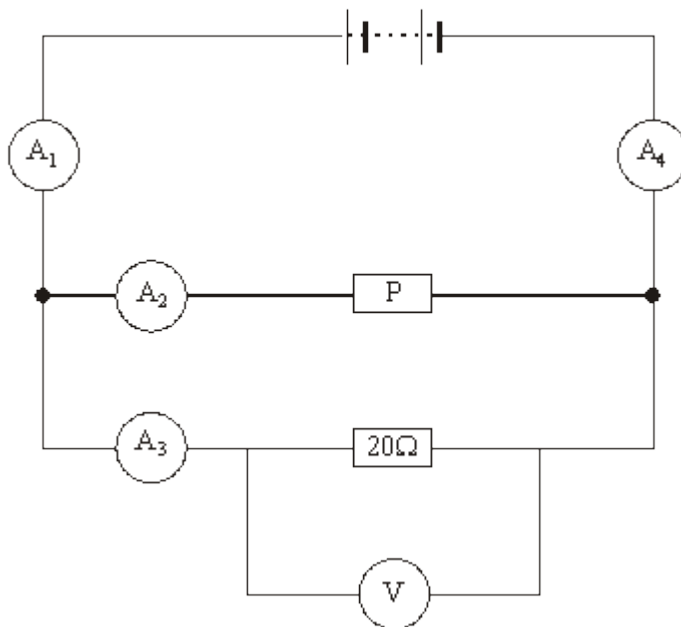

(a) The table gives the current through two of the ammeters.

(i) Complete the table to show the current through the other two ammeters.

Ammeter	Reading on ammeter in amps
A <sub>1</sub>	
A <sub>2</sub>	0.2
A <sub>3</sub>	0.3
A <sub>4</sub>	

(2)

(ii) Which **one** of the following statements is correct. Tick (✓) the box next to your choice.

The resistance of **P** is more than 20 Ω.

The resistance of **P** is equal to 20 Ω.

The resistance of **P** is less than 20 Ω.

Give a reason for your choice.

.....

.....

.....

(2)

(b) (i) Write down the equation that links current, potential difference and resistance.

.....

(1)

(ii) Calculate the reading on the voltmeter. Show clearly how you work out your answer.

.....

.....

Voltmeter reading = .....

(2)

(iii) State the potential difference of the power supply.

.....

(1)

(c) A second circuit contains an unknown component labelled **X**.

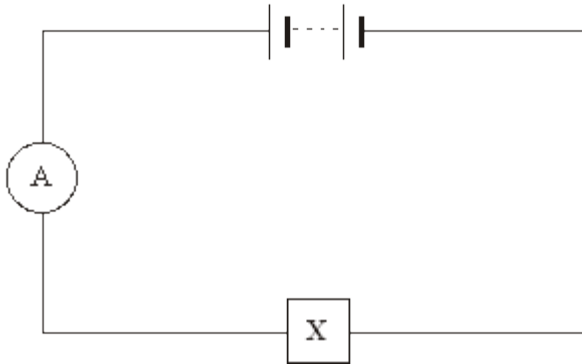

As component **X** is heated, the reading on the ammeter goes up.

What is component **X**?

.....

Give a reason for your answer.









.....

.....

(2)  
(Total 10 marks)

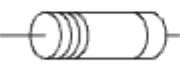
14

(a) Draw lines to join the picture to the correct circuit symbol. The lamp has been done for you.

Variable resistor		
Diode		
Resistor		
Lamp		

(2)

(b) A family tent is to be fitted with a simple lighting circuit.

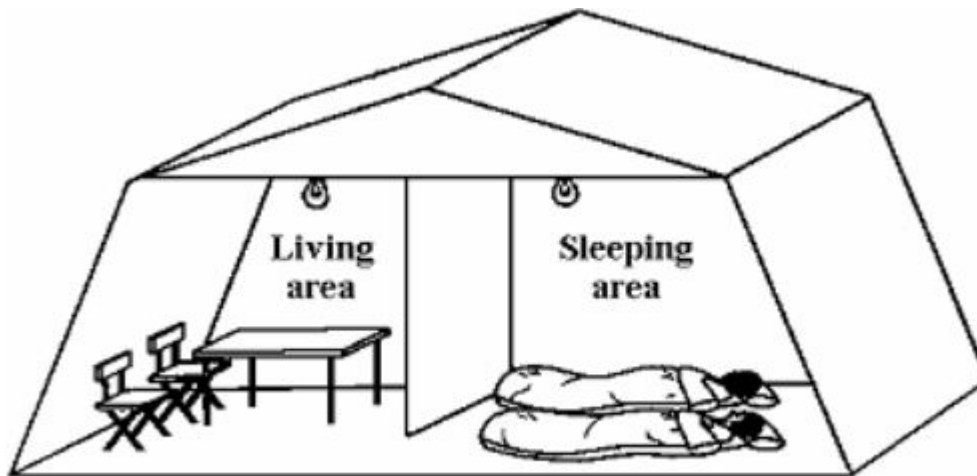

The diagram shows the first circuit used.

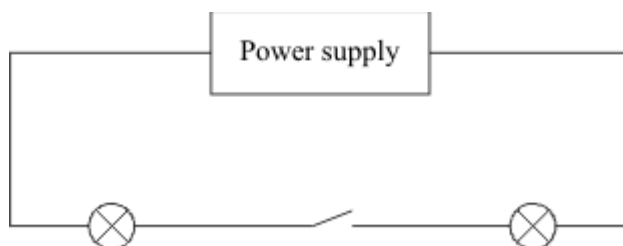

(i) Are the lamps connected in series or in parallel?

.....

(1)

(ii) This is not a good circuit for using in the tent. Why?

.....

.....

(1)

The diagram shows the second circuit used.

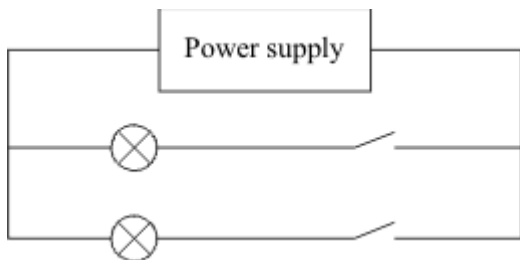

(iii) Give **two** reasons why this circuit is better than the first circuit.

1. ....

.....

2. ....

.....

(2)

(Total 6 marks)

15

(a) The diagram shows the voltage-current graphs for three different electrical components.

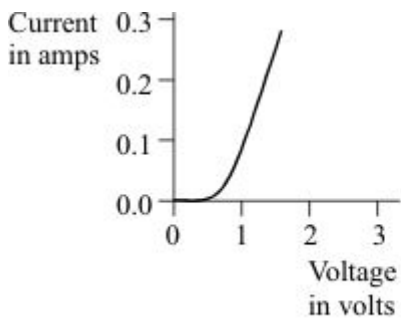

A

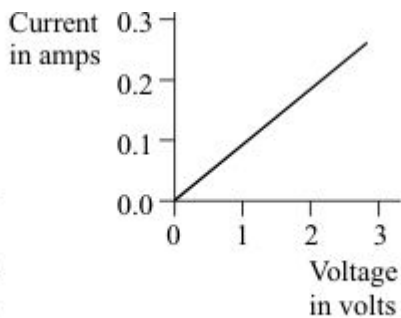

B

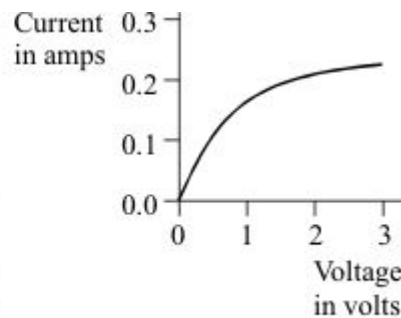

C

Which **one** of the components **A**, **B** or **C** could be a 3 volt filament lamp? Explain the reason for your choice.

.....  
.....  
.....  
.....

(3)

- (b) Using the correct symbols draw a circuit diagram to show how a battery, ammeter and voltmeter can be used to find the resistance of the wire shown.

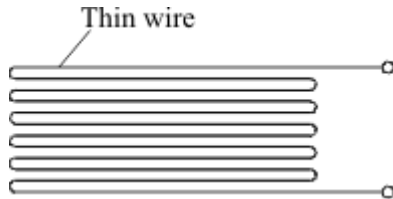

(3)

- (c) When correctly connected to a 9 volt battery the wire has a current of 0.30 amperes flowing through it.

- (i) Give the equation that links current, resistance and voltage.

.....

(1)

- (ii) Calculate the resistance of the wire. Show clearly how you work out your answer and give the unit.

.....  
.....

Resistance = .....

(3)

- (iii) When the wire is heated, the current goes down to 0.26 amperes. State how the resistance of the wire has changed.

.....  
.....

(1)

(Total 11 marks)



16

The diagram below shows how one type of fuel gauge in a car works. A sliding contact makes contact with a resistance wire wound in a coil (rheostat). It is connected to a float via a pivot P. When the petrol level changes the circuit resistance changes. This causes the pointer in the fuel gauge to move and show how much petrol is in the petrol tank.

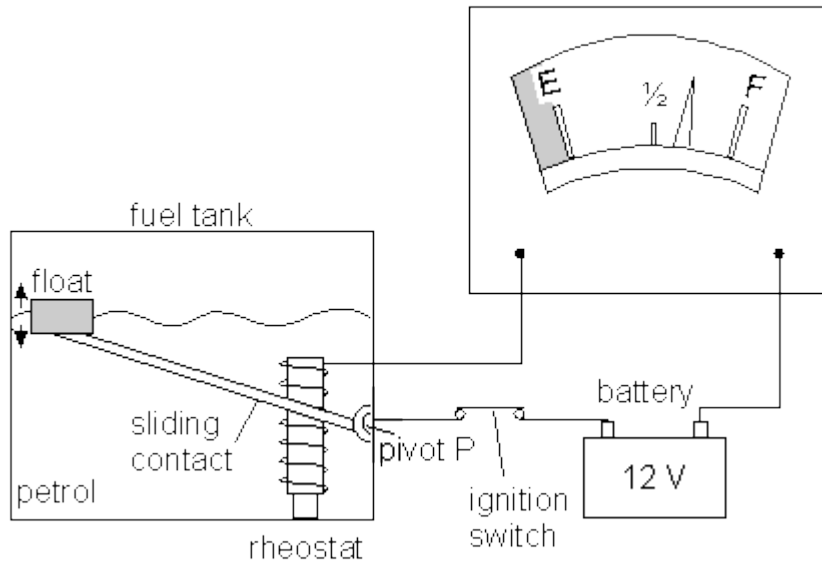

The circuit diagram is shown below.

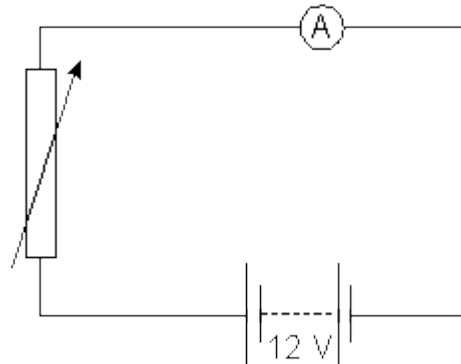

The petrol gauge is an ammeter. Explain why the reading on the ammeter falls as the petrol is used.

.....

.....

.....

.....

(Total 3 marks)

17

The circuit diagram below shows a circuit used to supply electrical energy to the two headlights of a car.

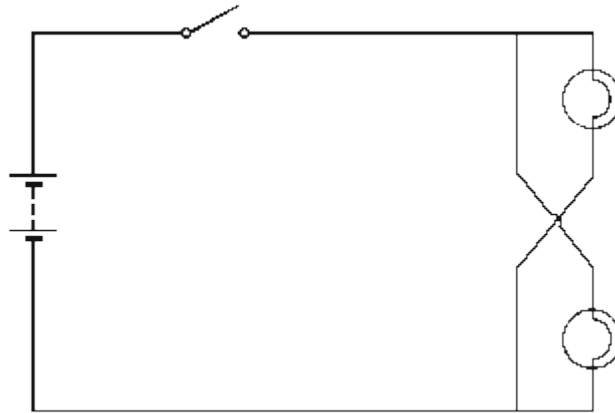

The current through the filament of one car headlight is 3.0 A. The potential difference across each of the two headlights is 12 V.

(a) Suggest a suitable fuse for the circuit. ....

(1)

(b) Calculate the resistance of the headlight filament when in use.

.....  
.....  
.....  
.....

Answer ..... W

(2)

(c) Calculate the power supplied to the two headlights of the car.

.....  
.....  
.....

Answer ..... W

(2)

- (d) The fully charged car battery can deliver 72 kJ of energy at 12 V. How long can the battery keep the headlights fully on?

.....  
.....  
.....

Answer ..... s

(2)  
(Total 7 marks)

18

When a mains lamp is switched on it takes 0.5 seconds for the filament to reach its normal operating temperature. The way in which the current changes during the first second after switching on is shown in the sketch graph below. Mains voltage is 240 V.

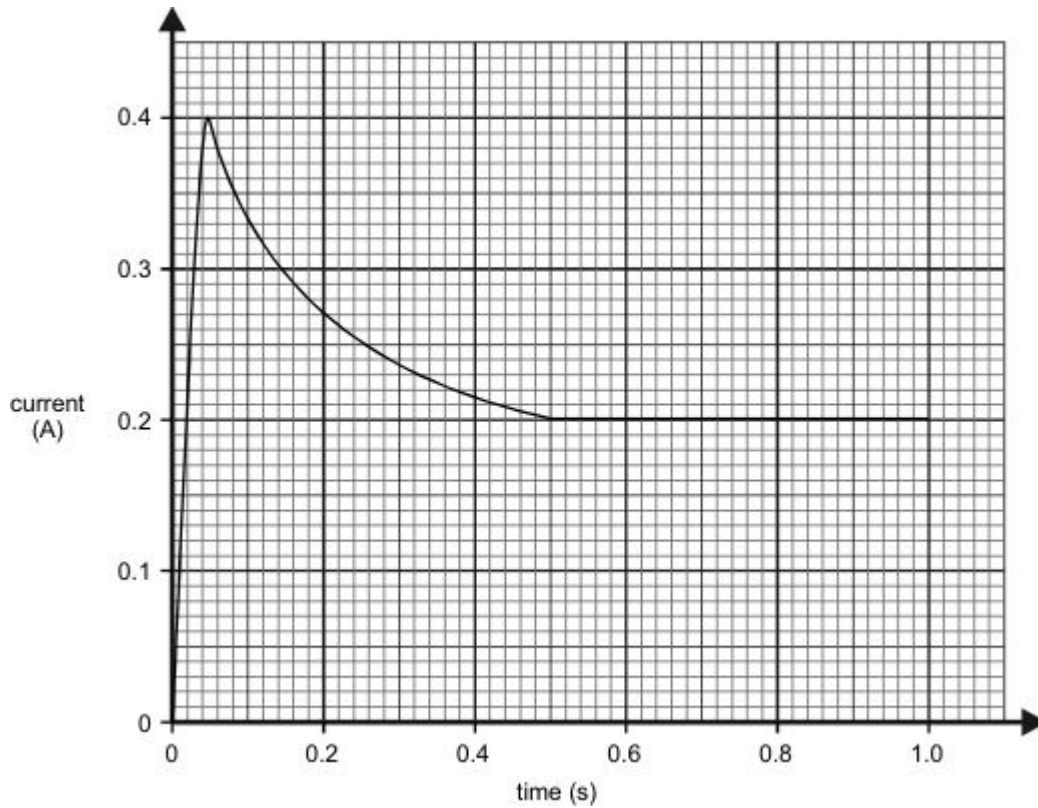

- (a) Calculate the resistance of the filament whilst the lamp is drawing the **maximum** current.

.....  
.....  
.....

(3)

- (b) Describe how the resistance of the lamp changes after the current has reached its maximum value.

.....  
.....

(2)

- (c) Calculate the **maximum** power taken by the lamp.

.....  
.....  
.....

(2)

- (d) Calculate the power of the lamp in normal use.

.....  
.....  
.....

(2)

- (e) Calculate the energy used by the lamp in six hours of normal use.

.....  
.....  
.....

(3)

(Total 12 marks)

**19**

Some electronic calculators use light emitting diodes (LEDs) to display numbers. Each number in a display consists of up to seven LEDs. The LEDs are arranged as shown in the diagram below. The different numbers are formed by switching different LEDs on at the same time. The LEDs are labelled A to G.

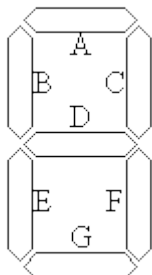

A simplified circuit to provide power to the LEDs is shown below.

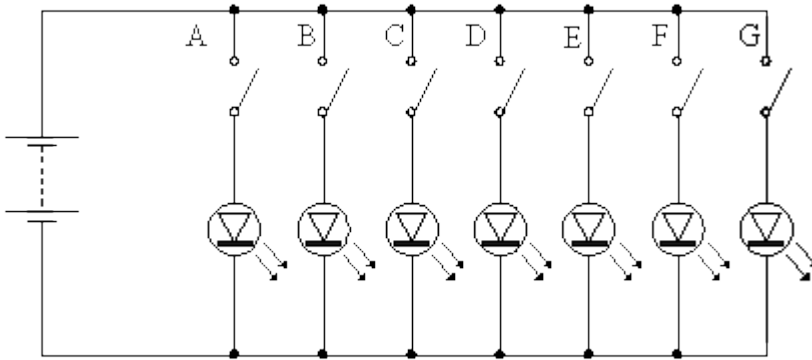

(a) Explain why each LED has its own switch.

.....  
.....

(2)

(b) What number is displayed when all switches except E are closed?

.....

(1)

(c) Which switches would be open if the number 3 is to be displayed?

.....

(1)

(d) Which of the numbers 0 to 9 draws least current from the battery? Explain your answer.

Number .....

Explanation .....

.....  
.....

(2)  
(Total 6 marks)

**20**

The circuit diagram below shows a battery connected to a lamp and a switch.

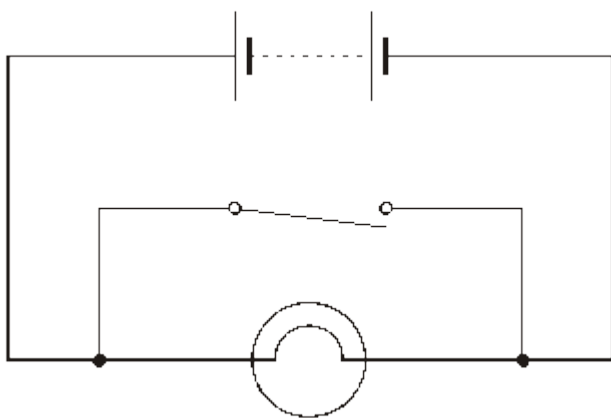

(a) State what happens to the lamp when:

(i) the switch is open (OFF);

.....

(ii) the switch is closed (ON).

.....

**(2)**

(b) When the switch is closed what problem is caused in the circuit?

.....  
 .....  
 .....

**(1)**

(c) In the space below draw a circuit diagram to show how the switch should be correctly connected to the lamp and battery.

**(1)**

**(Total 4 marks)**

**21**

(a) Complete the sentence below to name the instrument used to measure electrical current.

The instrument used to measure electrical current is called .....

**(1)**

- (b) In the diagram below each box contains an electrical component or a circuit symbol. Draw straight lines to link each electrical component to its circuit symbol. The first one has been done for you.

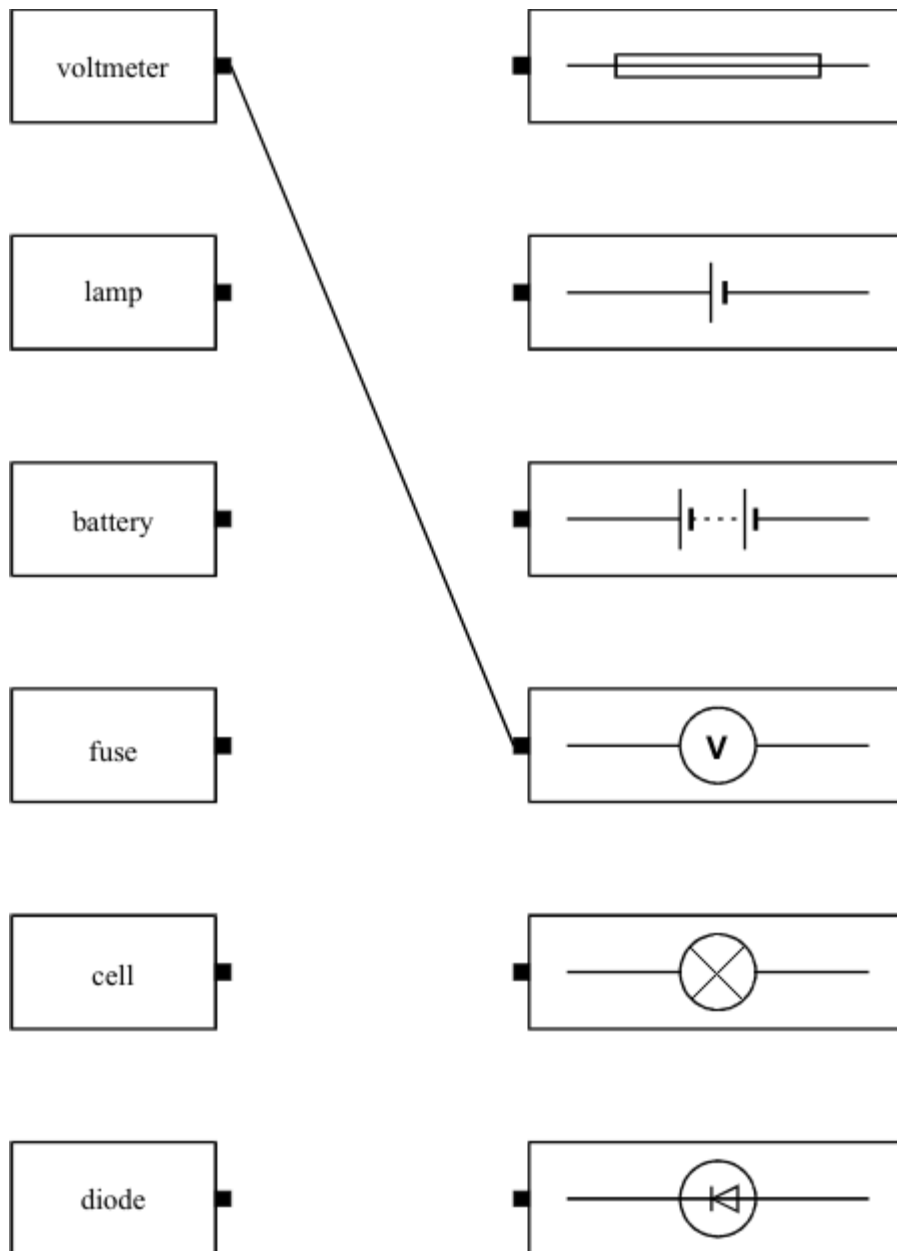

(4)  
(Total 5 marks)

22

A student investigates how the current flowing through a filament lamp changes with the voltage across it.

She is given a filament lamp and connecting wires.

She decides to use a 15V power supply, a variable resistor, an ammeter, a voltmeter and a switch.

(a) Complete the circuit diagram to show how she should set up the circuit.

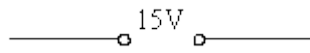

(4)

(b) The student obtains the following results.

VOLTAGE (V)	0.0	3.0	5.0	7.0	9.0	11.0
CURRENT (A)	0.0	1.0	1.4	1.7	1.9	2.1

(i) Plot a graph of current against voltage.

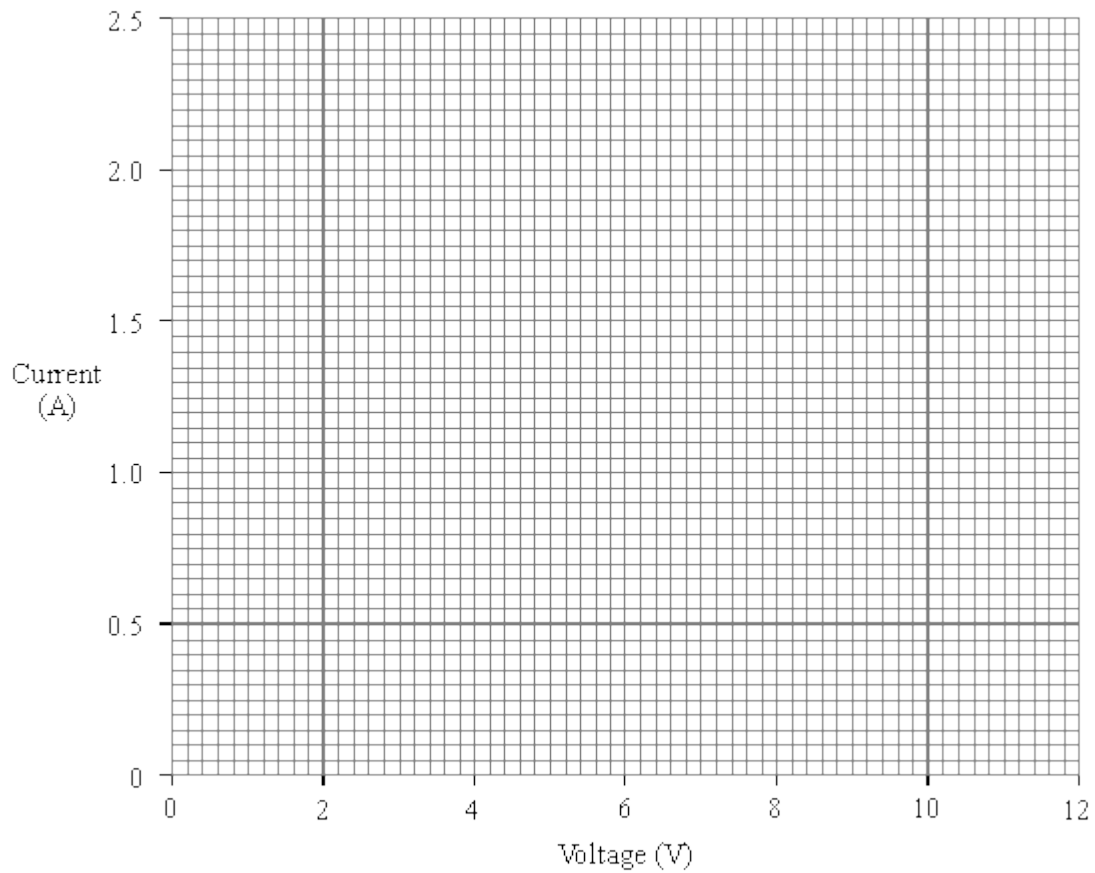

(3)



(ii) Use your graph to find the current when the voltage is 10V.

Current ..... A

(1)

(iii) Use your answer to (ii) to calculate the resistance of the lamp when the voltage is 10V.

.....  
.....  
.....

Resistance .....  $\Omega$

(2)

(c) (i) What happens to the resistance of the lamp as the current through it increases?

.....

(ii) Explain your answer.

.....  
.....  
.....

(2)

(Total 12 marks)

23

A bulb heats up when an electric current passes through the filament wire. The current was measured when different voltages were applied across the filament wire shown in the diagram below.

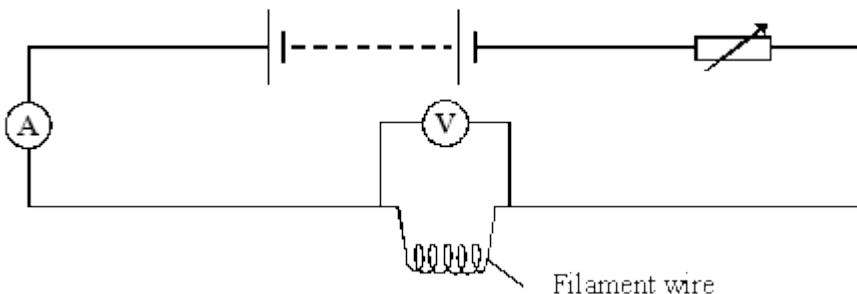

(a) (i) Look at the circuit diagram. How was the voltage changed?

.....  
.....

(1)

- (ii) Write an equation that shows the relationship between *current*, *potential difference* and *resistance*.

.....

(1)

- (b) The graph shows how the current through the filament wire changed as the potential difference across it changed.

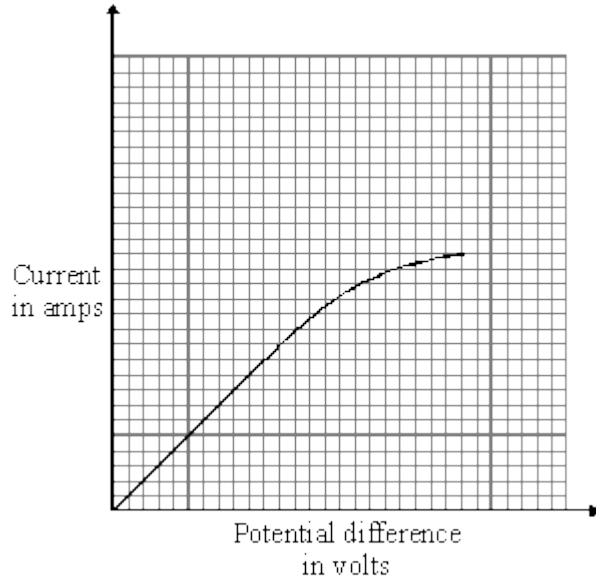

- (i) Describe the effect of increasing the potential difference on the current flowing through the filament wire.

.....  
.....  
.....

(2)

- (ii) Explain this effect in terms of the resistance of the filament wire.

.....  
.....  
.....

(2)  
(Total 6 marks)

24

The diagram shows a circuit.

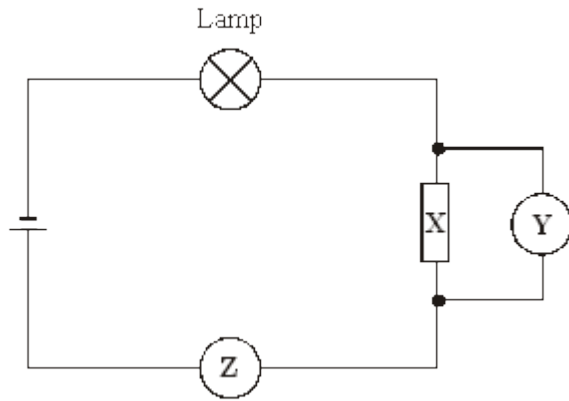

- (a) (i) Name component **X**. .....
- (ii) What does meter **Y** measure? .....
- (iii) What does meter **Z** measure? .....

(3)

- (b) Which of the equations shows how current, potential difference and resistance are related?

Tick the box against the correct equation.

current = potential difference  $\times$  resistance

potential difference = current  $\times$  resistance

resistance = current  $\times$  potential difference

(1)

(Total 4 marks)

25

The current through component **X** is measured when different voltages are applied across it.

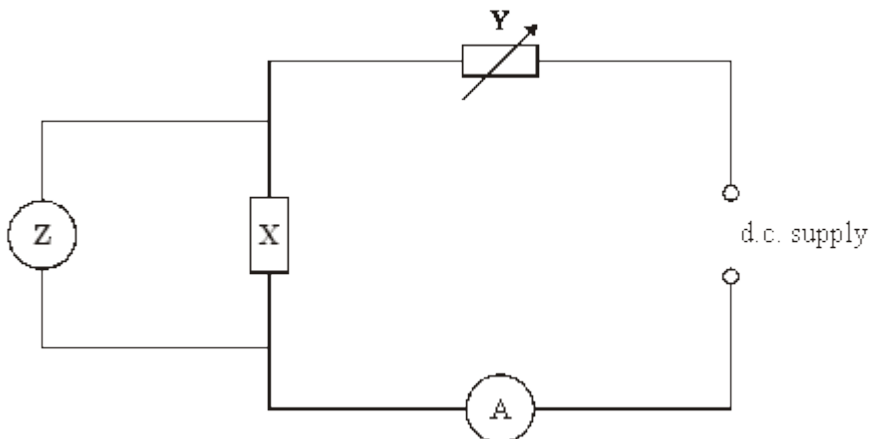

- (a) Name the component labelled **Y** in the circuit.

.....

(1)

- (b) What type of meter is **Z**?

.....

(1)

- (c) The table shows the measurements obtained in this experiment.

<b>Voltage in V</b>	0	0.2	0.4	0.6	0.8
<b>Current in mA</b>	0	0	50	100	150

Draw a graph of the measurements.

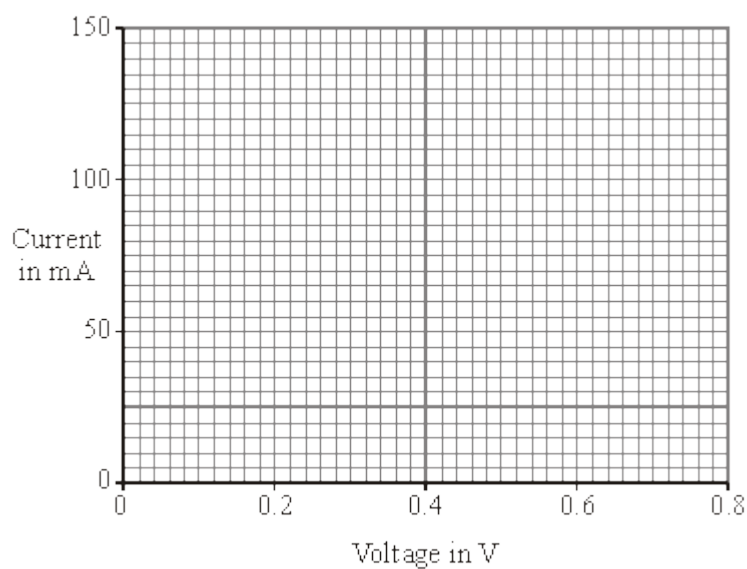

(2)

- (d) Use the shape of the graph to name component **X**.

.....

(1)

**(Total 5 marks)**

26

The diagram shows the fuel gauge assembly in a car.

- The sliding contact touches a coil of wire and moves over it.
- The sliding contact and the coil form a variable resistor.
- The sliding contact is connected to a float via a pivot.
- The fuel gauge indicator is an ammeter.
- When the petrol level changes, the resistance of the circuit changes.
- This causes the pointer in the fuel gauge indicator to move.

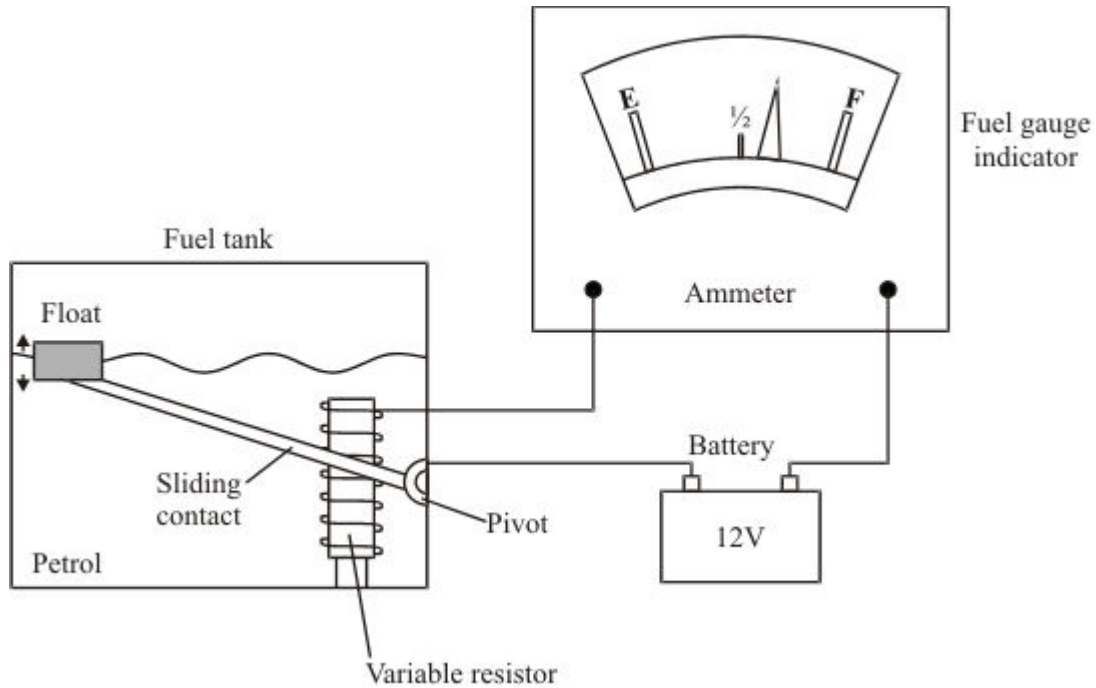

(a) Use standard symbols to draw a circuit diagram for the fuel gauge assembly.

**(3)**

(b) How will the current in the circuit change as the level of petrol in the tank falls?

.....

Explain the reason for your answer.

.....

.....

.....

**(2)**  
**(Total 5 marks)**

27

- (a) The diagram shows a simple circuit. Add an ammeter and a voltmeter to the circuit to show how to measure the current through the fixed resistor and the voltage across it.

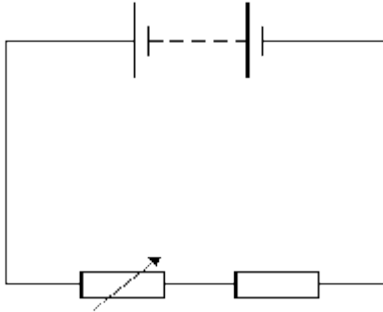

(2)

(b) An experiment using a circuit like the one above was set up. The following results were obtained when the resistance of the variable resistor was decreased.

(i) Draw a graph of the results below.

Voltage across fixed resistor in volts	Current in amps
0.50	0.10
0.75	0.15
1.00	0.20
1.25	0.25

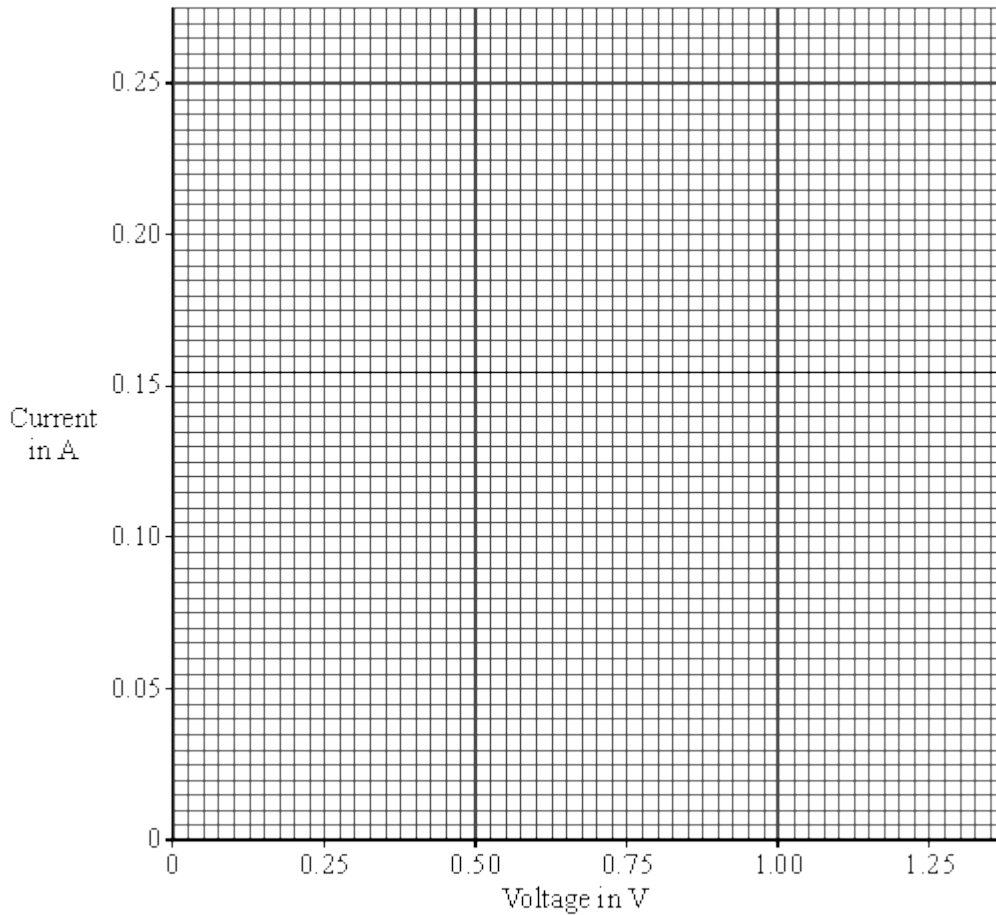

(2)

(ii) Use the graph to find the voltage when the current is 0.05 A.

Voltage = ..... V

(1)

(Total 5 marks)



**28**

The following specification is taken from the instruction booklet of a combination microwave oven.

AC voltage	240 V 50 Hz
Power required	
Microwave	1.5 kW
Dual (Roast/Bake)	2.8 kW
Dual (Grill)	2.5 kW
Convection	1.35 kW
Grill	2.3 kW
Output power	
Microwave	850 W
Convection heater	1350 W
Grill heater	1000 W
Microwave frequency	2450 MHz

(a) (i) What is the current when the oven is being used to cook in the dual (roast/bake) mode? Show clearly how you work out your answer.

.....  
 .....

Current = ..... A

**(2)**

(ii) Calculate the resistance of this combination microwave oven when it is being used in the dual (roast/bake) mode. Show clearly how you work out your answer and give the units.

.....  
 .....

Resistance = .....

**(3)**

(b) What is the percentage efficiency of the oven when it is working in the microwave mode?

.....  
.....  
.....

Percentage efficiency = ..... %

(2)  
(Total 7 marks)

29

A circuit was set up as shown in the diagram.

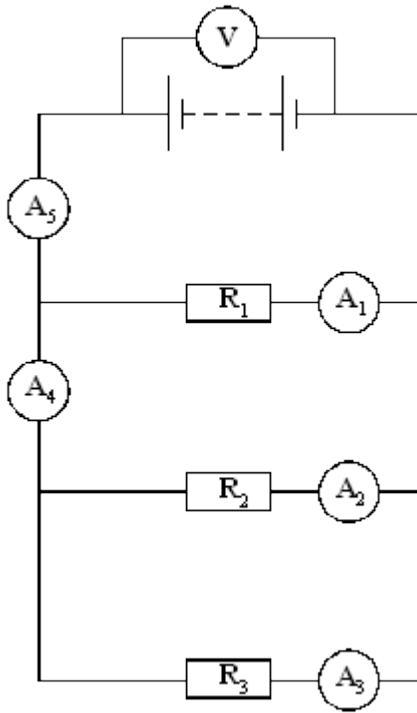

(a) The table gives the current through three of the ammeters. Complete the table to show the current through the other two ammeters.

Ammeter	Reading on ammeter in amps
$A_1$	0.2
$A_2$	0.6
$A_3$	0.3
$A_4$	
$A_5$	

(2)

(b) The reading on the voltmeter is 12 V.

What is the resistance of  $R_2$ ?

Show your working and include the correct unit.

.....

.....

.....

Resistance = .....

(3)

- (c) In the circuit above, the resistor  $R_2$  burned out and current stopped flowing in it. There was no other change to the circuit.

Complete the table below to show the readings on the ammeters after this took place.

Ammeter	Reading on ammeter in amps
$A_1$	0.2
$A_2$	0.0
$A_3$	
$A_4$	
$A_5$	

(3)  
(Total 8 marks)

30

The circuit contains three identical lamps.

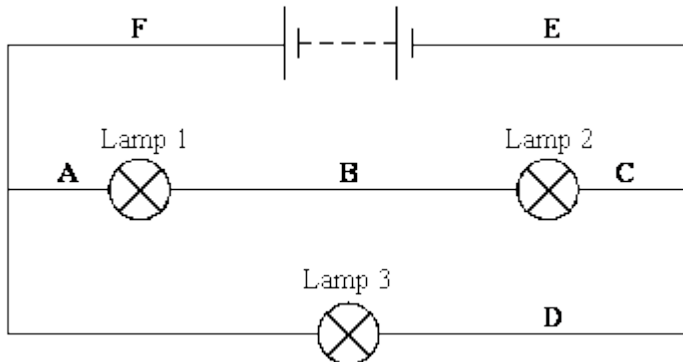

- (a) Complete each of the sentences about the circuit, using one of the phrases in the box.

more than	less than	the same as
-----------	-----------	-------------

- (i) The current at **A** is .....the current at **B**. (1)
- (ii) The current at **A** is .....the current at **D**. (1)
- (iii) The current at **F** is .....the current at **E**. (1)
- (iv) The current at **F** is .....the current at **D**. (1)

(b) In the circuit, which lamp is brightest?.....

Give a reason for your answer.

.....  
.....

(2)  
(Total 6 marks)

31

In a hairdryer circuit there is a heater and a motor. It is important that the motor is always running when the heater is switched on.

(a) Using the symbols shown below only **once** each, draw a circuit for a hairdryer.



(2)

(b) Modern hairdryers are described as *double insulated*.

Explain what this term means.

.....  
.....  
.....

(2)

(c) On a modern hairdryer handle it states:

1600 W      230 V      50 Hz

(i) [A] Write an equation which shows the relationship between current, power and voltage.

.....

(1)

[B] Calculate the current in the hairdryer when it is on full power.  
Show clearly how you get your answer.

.....  
.....

Current = ..... A

(2)

(ii) [A] Write an equation which shows the relationship between current, resistance and voltage.

.....

(1)

[B] The resistance of the heater is 20 ohms. Calculate the resistance of the motor.

Show clearly how you get your answer.

.....  
.....

Resistance = ..... ohms

(2)

(Total 10 marks)

32

The diagram shows a type of electric immersion heater in a hot water tank. These hot water tanks are normally found in airing cupboards.

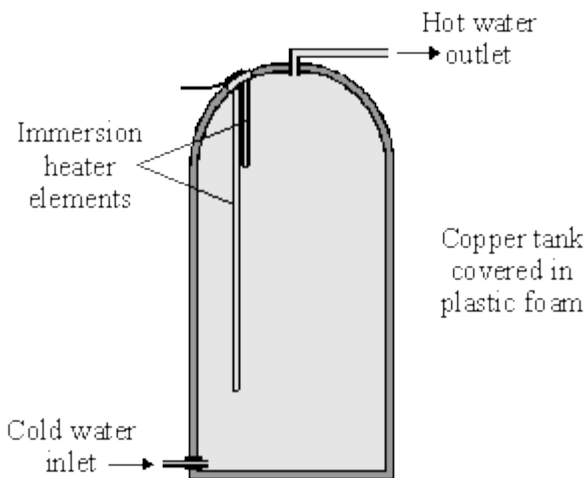

Information on the immersion heater states:

230 V  
10 A

(a) (i) What is the equation which shows the relationship between power, current and voltage?

.....  
(1)

(ii) Calculate the power of the heater. Show clearly how you get to your answer and give the units.

.....  
Power = .....  
(2)

(b) (i) What rating of fuse should be in the immersion heater circuit?

.....  
(1)

(ii) There are three wires in the cable to the immersion heater. Two of the wires are connected to the immersion heater. The third wire is connected to the copper tank.

Explain the function of this third wire and the fuse in the circuit.

.....  
.....  
.....  
.....  
(3)

(c) (i) What is the equation which shows the relationship between resistance, current and voltage?

.....  
(1)

(ii) Calculate the resistance of the heater. Show clearly how you get to your answer and give the units.

.....  
Resistance = .....  
(2)

**(Total 10 marks)**

33

The circuit contains two cells, an ammeter and a lamp. The reading on the ammeter is 0.2 A.

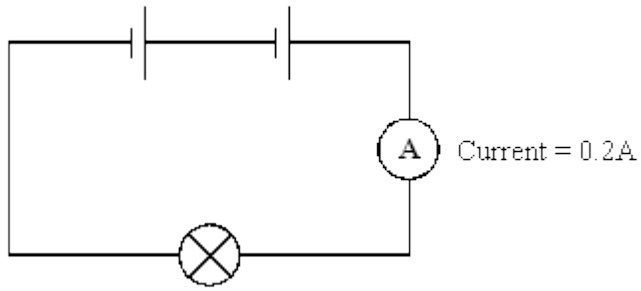

(a) What will be the reading on the ammeters in each of the circuits below?

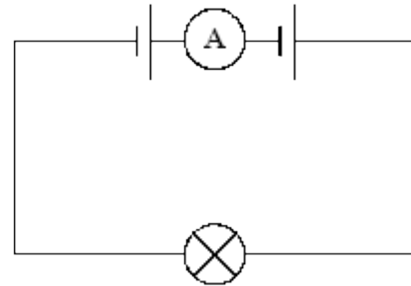
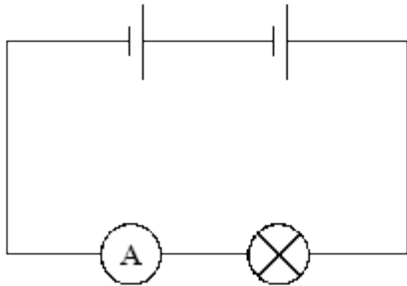

(i) Current is ..... A

(ii) Current is ..... A

(2)

(b) An ammeter was in a series circuit with two cells and a variable resistor.

The ammeter showed a reading of 0.3 A.

(i) Draw a circuit diagram for the circuit.

(2)

(ii) What will happen to the reading on the ammeter if the resistance of the variable resistor is **increased**?

.....

(1)

(Total 5 marks)



**34**

The diagram shows an electronic circuit.

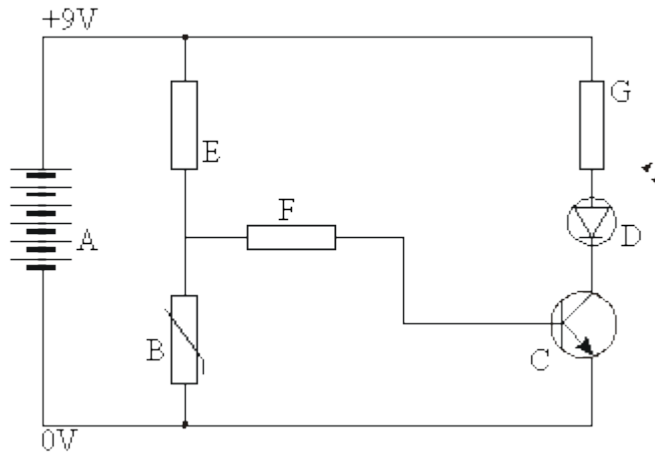

(a) Write down the names of the components in the list below.

- A = .....
- B = .....
- C = .....
- D = .....
- E, F and G = .....

(5)

(b) The graph shows how the resistance of component B depends on its temperature.

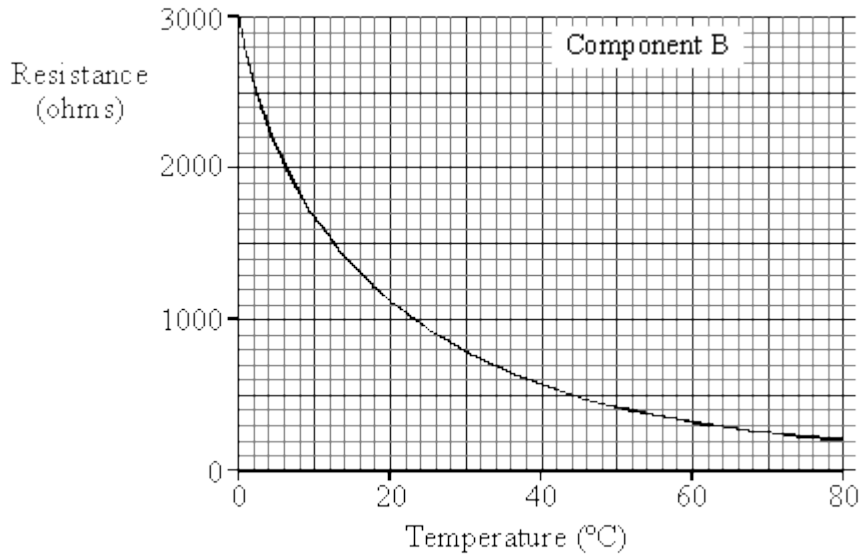

Describe, in as much detail as you can, how the resistance of component B changes as its temperature rises from 0°C to 80°C.

.....

.....

.....

.....

.....

(4)

(c) At what temperature does component B have a resistance of 1000 ohms?

Answer ..... °C .

(2)

(Total 11 marks)

35

A computer is set up to produce a graph of the current through an electric lamp during the first few milliseconds after it is switched on.

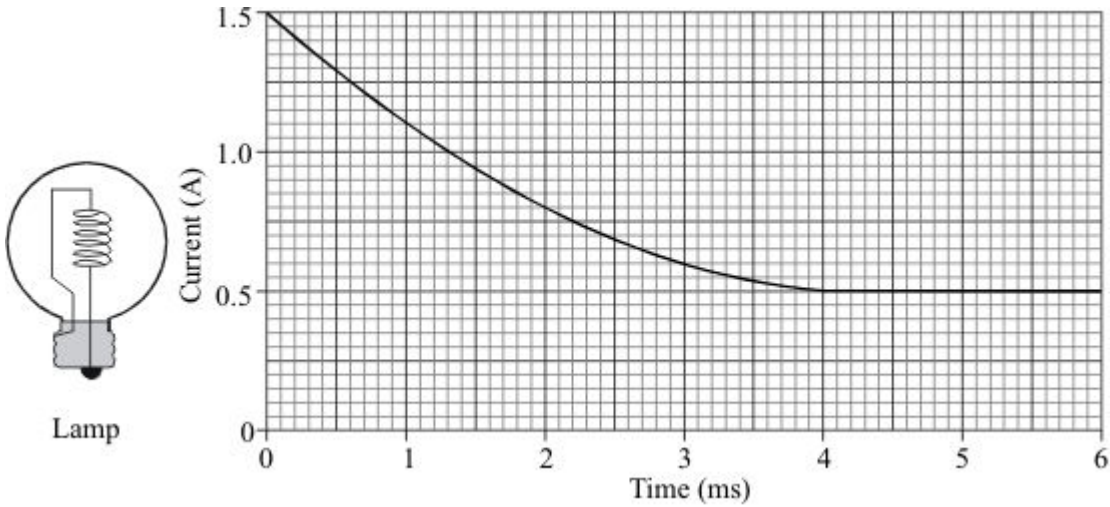

The lamp is modified then tested in the same way.

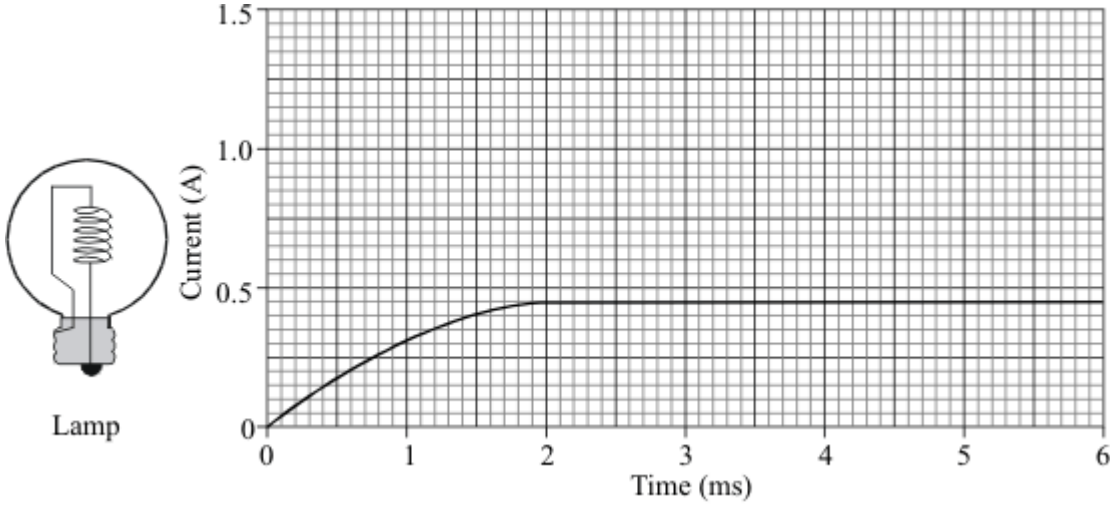

(a) Describe **three** differences in the way the lamp behaves after it has been modified.

1. ....
2. ....
3. ....

(3)

- (b) The current through the modified lamp depends on the total resistance of the filament and component X.

The smaller this total resistance is, the greater the current.

The following graphs show how the resistance of the lamp filament and component X change as the lamp heats up to its operating temperature.

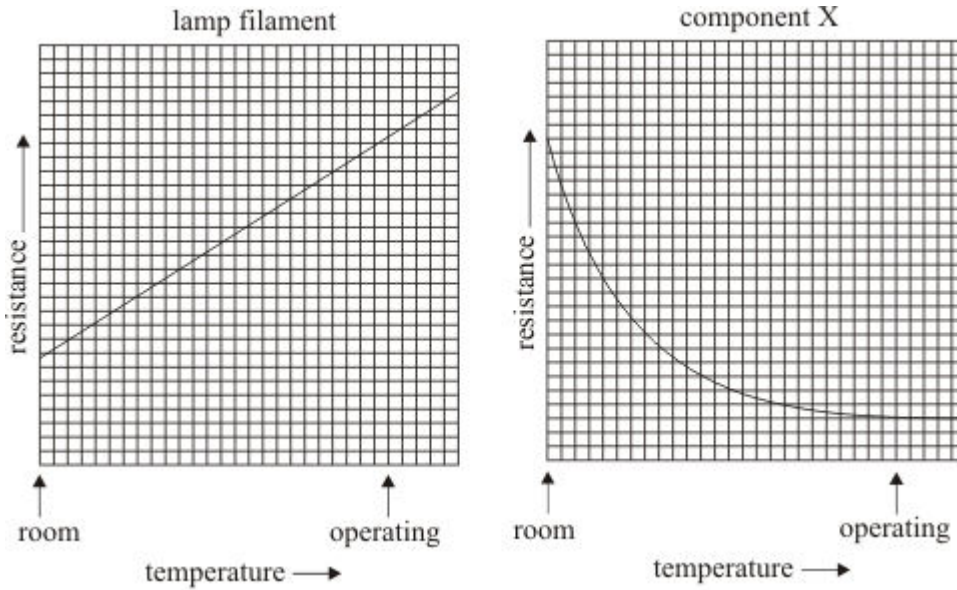

Use the information shown on the graphs to explain the behaviour of the modified lamp.

.....

.....

.....

.....

.....

.....

(4)  
(Total 7 marks)

**36** Label the parts of the electric circuit below.

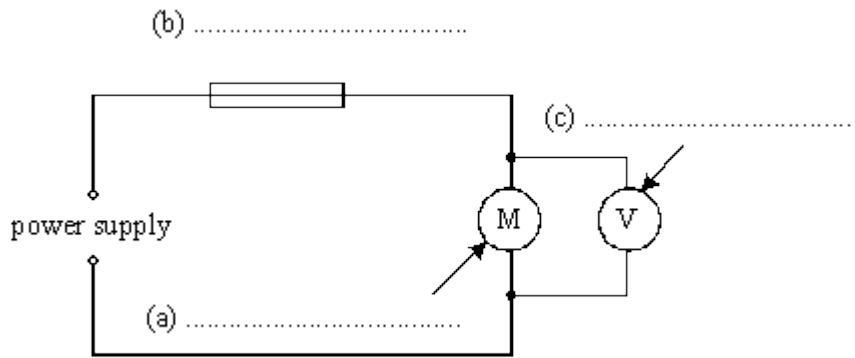

**(Total 3 marks)**

**37** (a) Add the missing labels to the diagram.

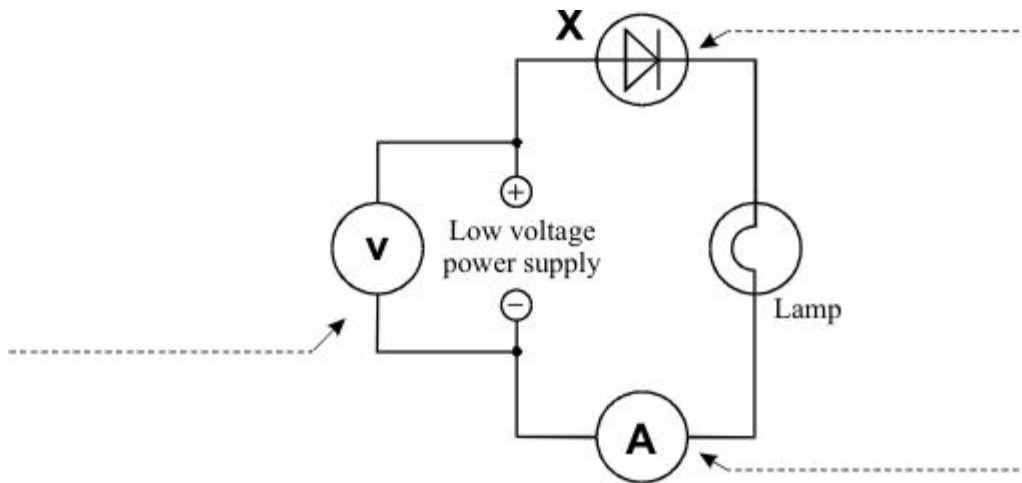

**(3)**

(b) Some students use the circuit shown above.

They want to find out how the current through component X changes as they change the voltage.

The graph shows their results.

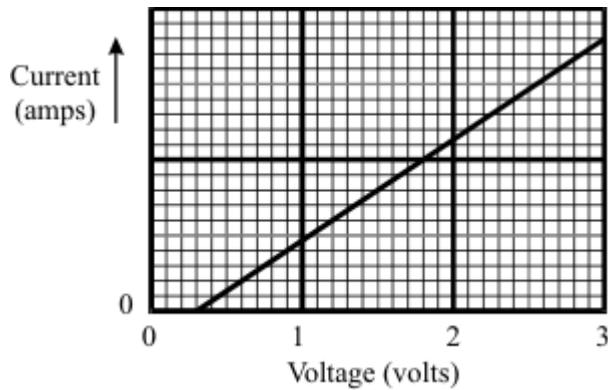

Describe, as fully as you can, what happens to the current through component X as the students increase the voltage.

.....

.....

.....

.....

.....

(4)  
(Total 7 marks)

**38**

Some students want to find out how the current through component X changes with the voltage they use.

The diagram shows their circuit. The graph shows their results.

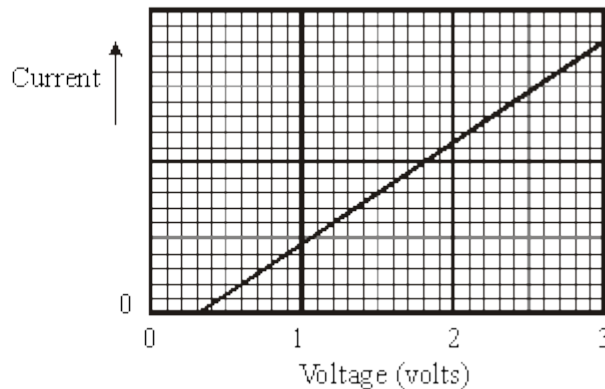
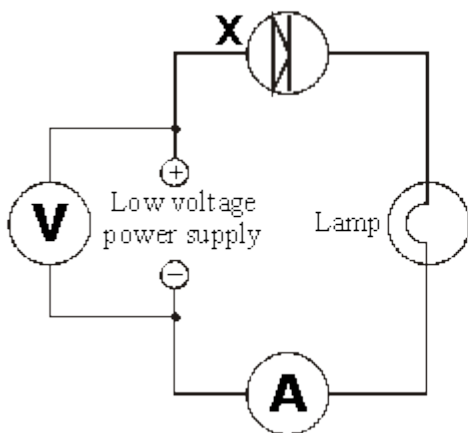

(a) Describe, as fully as you can, what happens to the current through component X as the students increase the voltage.

.....  
.....  
.....

(4)

(b) The students want to find out whether component X allows the same current to flow through it in the opposite direction.

(i) How should they change the circuit to test this?

.....

(1)

(ii) The graph shows the students' extra results.

What do the extra results tell you?

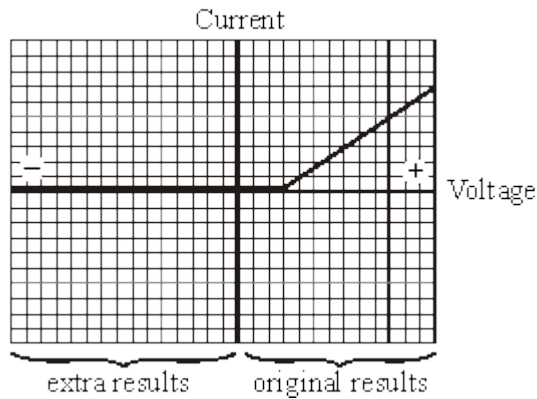

.....  
.....  
.....

(1)  
(Total 6 marks)

39

The diagram shows an electrical circuit.

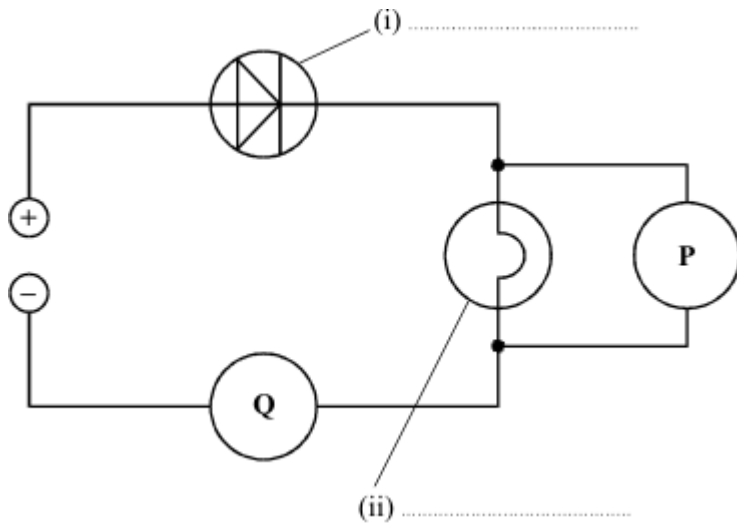

(a) Complete the two labels on the diagram.

(2)

(b) **P** and **Q** are meters.

What is meter **P** measuring? .....

What is meter **Q** measuring? .....

(2)

(Total 4 marks)

40

A small torch uses a single cell to make the bulb light up.

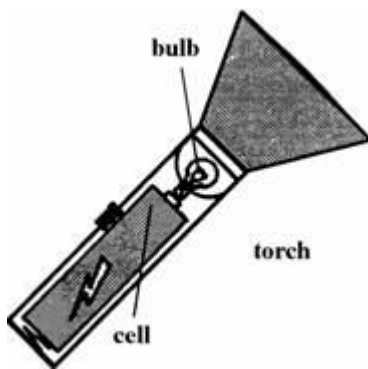

(a) Label the symbol for a cell and the symbol for a bulb (lamp)

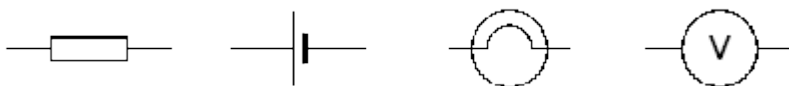

(2)



- (b) The graphs show the voltage across two different types of cell as they transfer the last bit of their stored energy through the torch bulb.

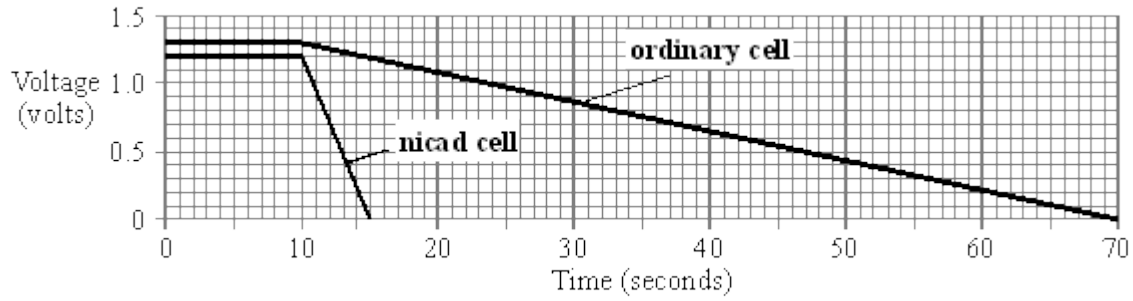

Describe the differences that the graphs show between the two types of cell.

.....

.....

.....

(3)

- (c) The diagram shows how bright the torch bulb is for different voltages.

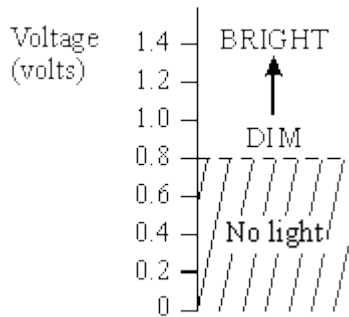

From the point when the voltage of each cell starts to fall, how long will the bulb stay lit:

- (i) with the ordinary cell?

.....

- (ii) with the nicad cell?

.....

(4)  
(Total 9 marks)

**41**

A small torch uses a single cell to make the bulb light up.

- (a) The graphs show the voltage across two different types of cell as they transfer the last bit of their stored energy through the torch bulb.

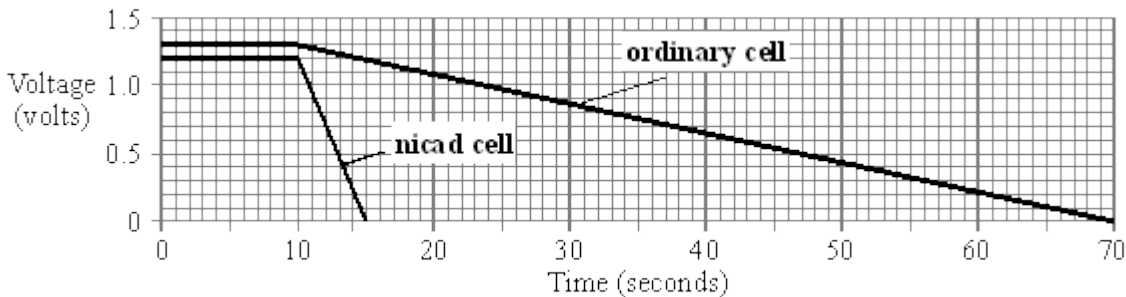

Describe the differences that the graphs show between the two types of cell.

.....

.....

**(3)**

- (b) The diagram shows how bright the torch bulb is for different voltages.

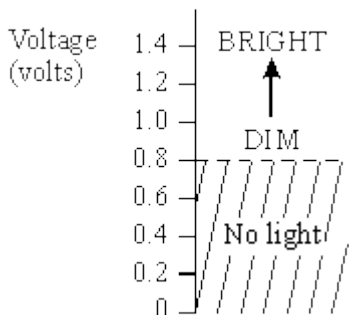

From the point when the voltage of each cell starts to fall, how long will the bulb stay lit:

- (i) with the ordinary cell?

.....

- (ii) with the nicad cell?

.....

**(4)**

(c) When the voltage across the bulb falls to half, the current through the bulb falls by **less than** half. Why is this?

.....

.....

.....

.....

**(3)**  
**(Total 10 marks)**