

1

Stars go through a life cycle.

Some stars will finish their life cycle as a black dwarf and other stars as a black hole.

(a) The table below gives the mass, relative to the Sun, of three stars, **J**, **K** and **L**.

Star	Mass of the star relative to the Sun
<b>J</b>	0.5
<b>K</b>	14.5
<b>L</b>	20.0

Which **one** of the stars, **J**, **K** or **L**, will become a black dwarf? .....

Give a reason for your answer.

.....  
.....

(2)

(b) Scientists can take the measurements needed to calculate the mass of many stars.

Scientists cannot calculate the mass of the star Betelgeuse.

They estimate that the star has a mass between 8 and 20 times the mass of the Sun.

(i) Betelgeuse is in the red super giant stage of its life cycle.

What will happen to Betelgeuse at the end of the red super giant stage?

.....  
.....

(1)

(ii) Suggest **one** reason why scientists can only estimate and **not** calculate the mass of Betelgeuse.

.....  
.....  
.....

(1)



(b) The isotope molybdenum-99 is produced inside some nuclear power stations from the nuclear fission of uranium-235.

(i) What happens during the process of nuclear fission?

.....  
.....

(1)

(ii) Inside which part of a nuclear power station would molybdenum be produced?

.....

(1)

(c) When the nucleus of a molybdenum-99 atom decays, it emits radiation and changes into a nucleus of technetium-99.

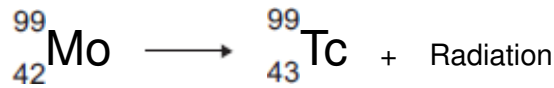

What type of radiation is emitted by molybdenum-99?

.....

Give a reason for your answer.

.....  
.....

(2)

(d) Technetium-99 has a short half-life and emits gamma radiation.

What is meant by the term 'half-life'?

.....  
.....  
.....

(1)

(e) Technetium-99 is used by doctors as a medical tracer. In hospitals it is produced inside a technetium generator by the decay of molybdenum-99 nuclei.

(i) The figure below shows how the number of nuclei in a sample of molybdenum-99 changes with time as the nuclei decay.

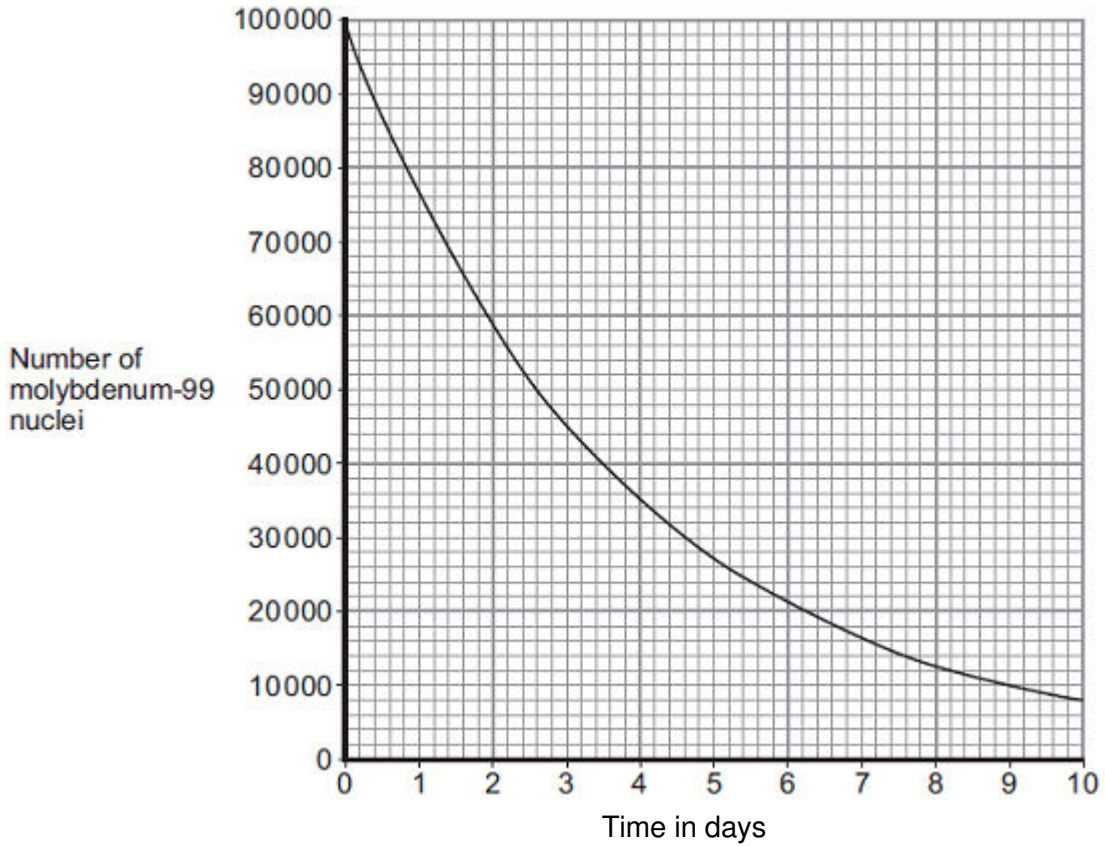

A technetium generator will continue to produce sufficient technetium-99 until 80% of the original molybdenum nuclei have decayed.

After how many days will a source of molybdenum-99 inside a technetium-99 generator need replacing?

Show clearly your calculation and how you use the graph to obtain your answer.

.....

.....

.....

Number of days = .....

(2)

- (ii) Medical tracers are injected into a patient's body; this involves some risk to the patient's health.

Explain the risk to the patient of using a radioactive substance as a medical tracer.

.....

.....

.....

.....

(2)

- (iii) Even though there may be a risk, doctors frequently use radioactive substances for medical diagnosis and treatments.

Suggest why.

.....

.....

(1)

(Total 11 marks)

**3**

Nuclear fission and nuclear fusion are two processes that release energy.

- (a) (i) Use the correct answer from the box to complete each sentence.

<b>Geiger counter</b>	<b>nuclear reactor</b>	<b>star</b>
-----------------------	------------------------	-------------

Nuclear fission takes place within a .....

Nuclear fusion takes place within a .....

(2)

- (ii) State **one** way in which the process of nuclear fusion differs from the process of nuclear fission.

.....

.....

(1)

(b) The following nuclear equation represents the fission of uranium-235 (U-235).

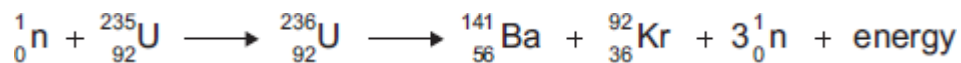

Chemical symbols:

Ba - barium

Kr - krypton

(i) Use the information in the equation to describe the process of nuclear fission.

.....

.....

.....

.....

.....

.....

.....

.....

.....

(4)

(ii) An isotope of barium is Ba-139.  
Ba-139 decays by beta decay to lanthanum-139 (La-139).

Complete the nuclear equation that represents the decay of Ba-139 to La-139.

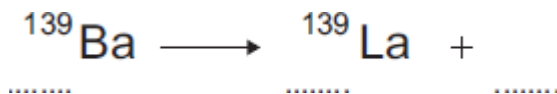

(3)  
(Total 10 marks)

4

Nuclear power stations use the energy released from nuclear fuels to generate electricity.

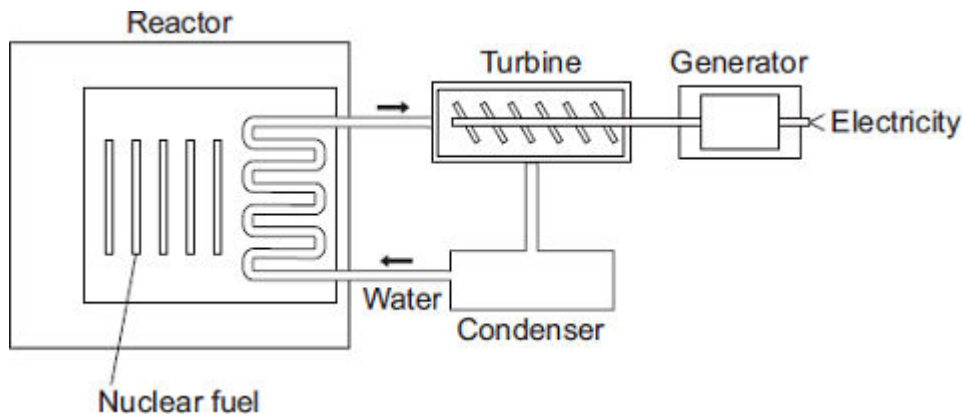

- (a) Which substance do the majority of nuclear reactors use as fuel?  
 Draw a ring around your answer.

**plutonium-239**

**thorium-232**

**uranium-235**

(1)

- (b) Energy is released from nuclear fuels by the process of nuclear fission.  
 Describe what happens to the nucleus of an atom during nuclear fission.

.....  
 .....  
 .....  
 .....

(2)

- (c) Use words from the box to complete each sentence.

<b>condenser</b>	<b>gas</b>	<b>generator</b>	<b>reactor</b>	<b>steam</b>	<b>turbine</b>
------------------	------------	------------------	----------------	--------------	----------------

The energy released from the nuclear fuel is used to heat water. The water turns into  
 ..... and this is used to drive a .....

This turns a ..... to produce electricity.

(3)  
 (Total 6 marks)

5

(a) Nuclear power stations generate about 14% of the world's electricity.

(i) Uranium-235 is used as a fuel in some nuclear reactors.

Name **one** other substance used as a fuel in some nuclear reactors.

.....

(1)

(ii) Energy is released from nuclear fuels by the process of nuclear fission.

This energy is used to generate electricity.

Describe how this energy is used to generate electricity.

Do **not** explain the nuclear fission process.

.....  
.....  
.....  
.....  
.....  
.....  
.....

(3)

(b) The diagram shows the nuclear fission process for an atom of uranium-235.

Complete the diagram to show how the fission process starts a chain reaction.

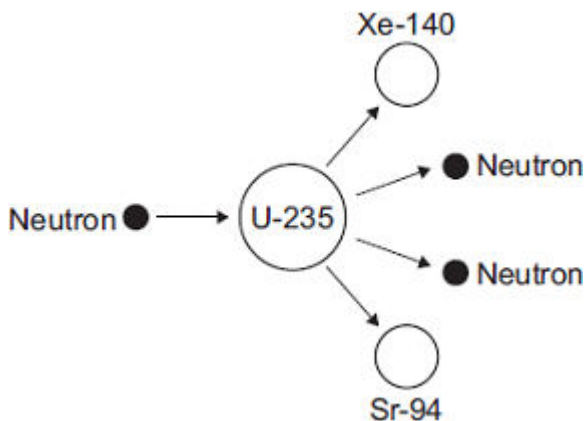

(2)



(c) The diagram shows the cross-section through a nuclear reactor.

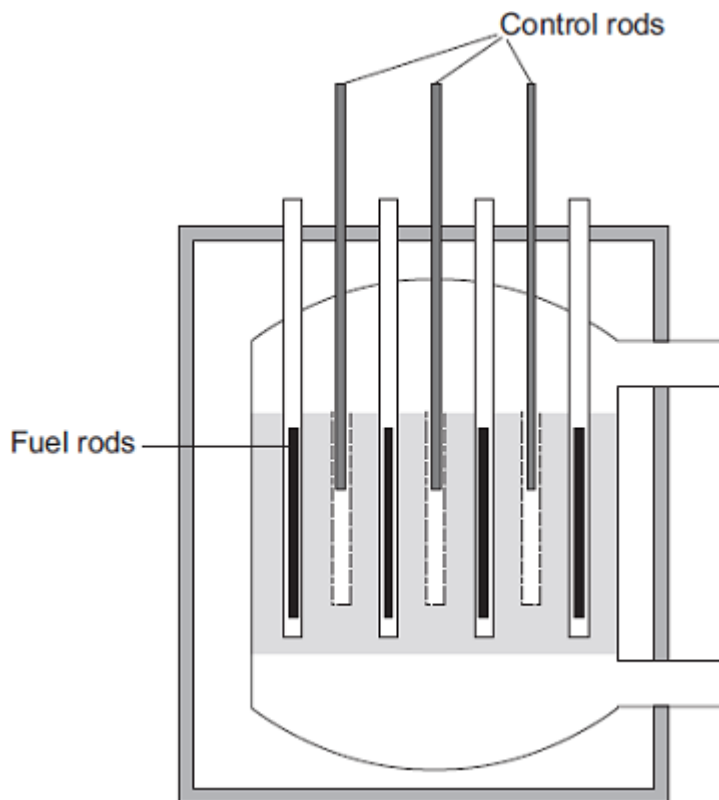

The control rods, made from boron, are used to control the chain reaction. Boron atoms absorb neutrons without undergoing nuclear fission.

Why does lowering the control rods reduce the amount of energy released each second from the nuclear fuel?

.....  
.....  
.....  
.....

(2)  
(Total 8 marks)

**6**

Stars go through a life cycle. About 90 % of all stars are in the 'main sequence' period of the life cycle.

(a) Stars are stable during the 'main sequence' period of the life cycle.

Why?

.....  
.....

(1)

- (b) The table gives an estimated time for the number of years that three stars, **X**, **Y** and **Z**, will be in the 'main sequence' period of their life cycle.

Star	Relative mass of the star compared to the Sun	Estimated 'main sequence' period in millions of years
<b>X</b>	0.1	4 000 000
<b>Y</b>	1.0	9 000
<b>Z</b>	40.0	200

- (i) This data suggests that there is a pattern linking the mass of a star and the number of years the star is in the 'main sequence' period of its life cycle.

What is the pattern suggested by the data?

.....  
.....

(1)

- (ii) Scientists cannot give the exact number of years a star will be in the 'main sequence' period.

Suggest why.

.....  
.....

(1)

(iii) Nuclear fusion is the process by which energy is released in stars.

Which **one** of the following can be concluded from the data in the table?

Draw a ring around the correct answer in the box to complete the sentence.

The rate of nuclear fusion in a large star is 

faster than
the same as
slower than

 in a small star.

Explain the reason for your answer.

.....  
.....  
.....  
.....

(3)

(c) *In this question you will be assessed on using good English, organising information clearly and using specialist terms where appropriate.*

Describe what happens to a star **much bigger** than the Sun, once the star reaches the end of the 'main sequence' period of its life cycle.

Your answer should include the names of the stages the star passes through.

.....  
.....  
.....  
.....  
.....  
.....  
.....  
.....

(6)  
(Total 12 marks)

7

Read this statement from a website.

Immediately after the 'big bang', at the start of the Universe, there were only atoms of the element hydrogen (H).  
Now there are over one hundred elements.  
Scientists think that all the elements on Earth are also present throughout the Universe.

(a) Explain how atoms of the element (He) are formed in a star.

.....  
.....  
.....  
.....

(2)

(b) Explain how atoms of very heavy elements, such as gold (Au), were formed.

.....  
.....  
.....  
.....

(2)

(c) Scientists have only examined a tiny fraction of the Universe.

What is the basis for scientists thinking that the elements found on Earth are present throughout the Universe?

.....  
.....

(1)

(Total 5 marks)

**8**

- (a) Nuclear fuels and the wind are two of the energy sources used to generate electricity in the UK.

Explain the advantages of using energy from nuclear fuels to generate electricity rather than using energy from the wind.

Include in your answer a brief description of the process used to generate electricity from nuclear fuels.

.....  
.....  
.....  
.....  
.....  
.....  
.....  
.....

**(4)**

- (b) In the UK, most electricity is generated in power stations that emit carbon dioxide into the atmosphere. The impact of these power stations on the environment could be reduced by the increased use of 'carbon capture' technology.

Describe how 'carbon capture' would prevent the build-up of carbon dioxide in the atmosphere.

.....  
.....  
.....  
.....  
.....

**(2)**

**(Total 6 marks)**

9

(a) Nuclear fission is used in nuclear power stations to generate electricity. Nuclear fusion happens naturally in stars.

(i) Explain briefly the difference between *nuclear fission* and *nuclear fusion*.

.....  
.....  
.....  
.....  
.....

(2)

(ii) What is released during both nuclear fission and nuclear fusion?

.....

(1)

(b) Plutonium-239 is used as a fuel in some nuclear reactors.

(i) Name another substance used as a fuel in some nuclear reactors.

.....

(1)

(ii) There are many isotopes of plutonium.

What do the nuclei of different plutonium isotopes have in common?

.....

(1)

(Total 5 marks)

10

(a) The diagram shows the lifecycle of a star.

(i) Use words or phrases from the box to complete the sentences contained in the diagram.

**black dwarf      black hole      protostar      red giant**

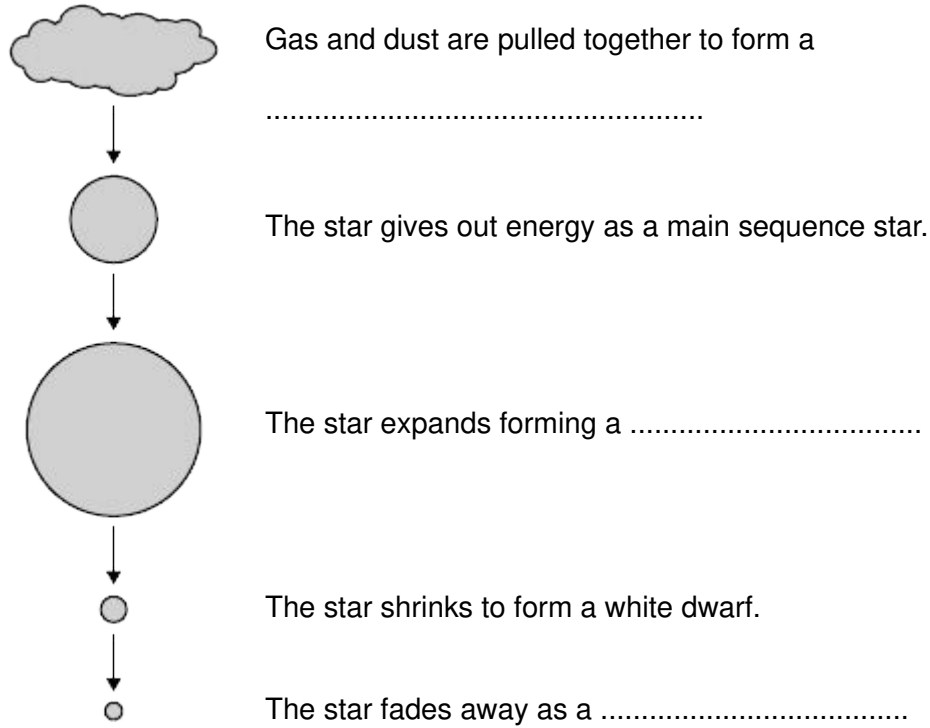

(3)

(ii) The table compares the approximate size of three stars with the size of the Sun.

Star	Size
Alpha Centauri A	the same as the Sun
Betelgeuse	1120 times bigger than the Sun
Cephei	1520 times bigger than the Sun

Which **one** of these three stars has the lifecycle shown in part (a)(i)?

.....

Give a reason for your answer.

.....

.....

(2)

(b) Which one of the following describes the process by which energy is given out in stars?

Tick (✓) **one** box.

Atomic nuclei inside the star join together.

Atomic nuclei inside the star split apart.

Gases inside the star burn.

(1)  
(Total 6 marks)

**11**

(a) As part of its life cycle, a star changes from being a protostar to a main sequence star.

Explain the difference between a protostar and a main sequence star.

.....  
.....  
.....  
.....

(2)

(b) The early Universe contained only atoms of hydrogen. The Universe now contains atoms of over one hundred different elements.

Explain how the different elements now contained in the Universe were formed.

.....  
.....  
.....  
.....  
.....  
.....

(3)  
(Total 5 marks)



**12**

The names of three different processes are given in **List A**.  
Where these processes happen is given in **List B**.

Draw a line to link each process in **List A** to where the process happens in **List B**.

Draw only **three** lines.

<b>List A</b>	<b>List B</b>
<b>Process</b>	<b>Where it happens</b>
fusion	in a star
chain reaction	in a nuclear reactor
alpha decay	in a smoke precipitator
	in the nucleus of an atom

**(Total 3 marks)**

13

The flowchart shows a simple version of the life cycle of a star that is much more massive than the Sun.

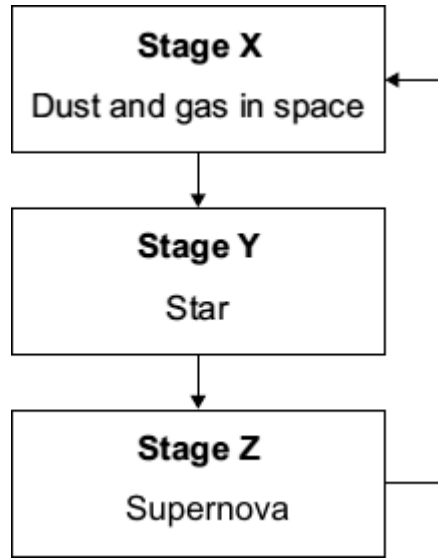

(a) What causes the change from **Stage X** to **Stage Y**?

.....

(1)

(b) For most of its time in **Stage Y**, the star is stable.

Explain why the star remains stable.

.....  
.....  
.....  
.....

(2)

(c) (i) Explain how a star is able to produce energy in **Stage Y**.

.....  
.....  
.....  
.....

(2)

(ii) Why is a star in **Stage Y** able to give out energy for millions of years?

.....  
.....

(1)

(d) What happens to the elements produced in a supernova?

.....  
.....

(1)  
(Total 7 marks)

14

When the nucleus of a radium-225 atom decays, it changes into a nucleus of actinium-225.

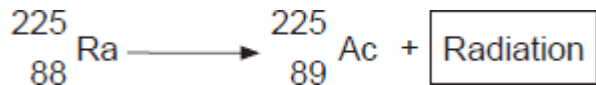

What type of radiation is emitted by radium-225?

Draw a ring around your answer.

**alpha**                      **beta**                      **gamma**

Explain the reason for your answer.

.....  
.....  
.....  
.....  
.....  
.....

(Total 3 marks)

15

This passage is from a web page.

### Our nearest star, the Sun

The pie chart shows the proportions of chemical elements in the Sun.

Chemical Element	Proportion
Hydrogen	75%
Helium	23%
Other elements	2%

Most of the Sun's helium has been produced from the Sun's hydrogen by the process of nuclear fusion. This process also produces vast quantities of energy. The process takes place in the core of the Sun at a temperature of about 15 million °C and has been going on for about 4.5 billion years. During this period of time, the Sun has remained stable and scientists think that it will remain stable for several billion years into the future.

(a) Explain why the Sun remains stable.

.....

.....

.....

.....

(3)

(b) A scientific opinion is expressed on this web page.

Identify this opinion and suggest how scientists could justify it.

.....

.....

.....

.....

(2)  
(Total 5 marks)

16

The process of nuclear fusion results in the release of energy.

(a) (i) Describe the process of nuclear fusion.

.....  
.....  
.....  
.....

(2)

(ii) Where does nuclear fusion happen naturally?

.....

(1)

(b) For many years, scientists have tried to produce a controlled nuclear fusion reaction that lasts long enough to be useful. However, the experimental fusion reactors use more energy than they produce.

(i) From the information given, suggest **one** reason why nuclear fusion reactors are not used to produce energy in a nuclear power station.

.....  
.....

(1)

(ii) Suggest **one** reason why scientists continue to try to develop a practical nuclear fusion reactor.

.....  
.....

(1)

**(Total 5 marks)**

**17**

(a) Our star, the Sun, is stable.

Explain what the conditions need to be for a star to remain stable.

.....  
.....  
.....  
.....  
.....  
.....

**(2)**

(b) Shortly after the 'big bang', hydrogen was the only element in the Universe.

Explain how the other elements came to be formed.

.....  
.....  
.....  
.....  
.....  
.....  
.....  
.....

**(3)**

**(Total 5 marks)**

**18**

(a) Uranium atoms do not always have the same number of neutrons.

What are atoms of the same element that have different numbers of neutrons called?

.....

**(1)**

(b) By emitting an alpha particle, an atom of uranium-235 decays into an atom of thorium.

An alpha particle, which is the same as a helium nucleus, is represented by the symbol



The decay can be represented by the equation below.

Complete the equation by writing the correct number in each of the two boxes.

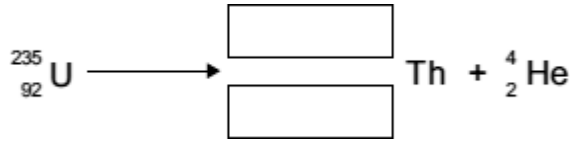

(2)

(c) The diagram shows an atom of uranium-235 being split into several pieces.

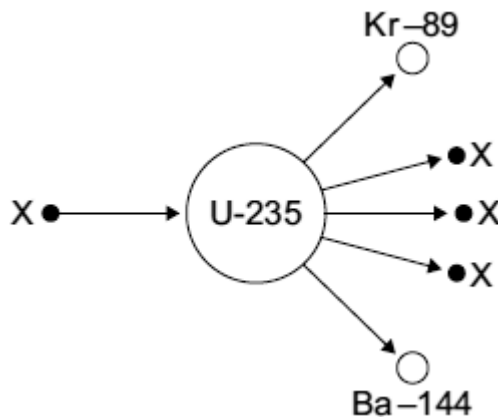

(i) Name the process shown in the diagram.

.....

(1)

(ii) Name the particles labelled X.

.....

(1)

(d) Uranium-235 is used as a fuel in some nuclear reactors.

Name another substance used as a fuel in some nuclear reactors.

.....

(1)

**(Total 6 marks)**

**19**

Every star goes through a 'life cycle'.

(a) Describe how a star forms.

.....  
.....  
.....  
.....  
.....

**(2)**

(b) During a long period of its life, a star remains in a stable state.

Explain why a star remains stable.

.....  
.....  
.....  
.....  
.....

**(2)**

(c) Some stars are much more massive than the Sun.

Describe what will happen to a star, originally much more massive than the Sun, after it reaches its red giant stage.

.....  
.....  
.....  
.....  
.....

**(2)**

**(Total 6 marks)**



20

Four different processes are described in **List A**. The names of these processes are given in **List B**.

Draw a line to link each description in **List A** to its correct name in **List B**.  
Draw only **four** lines.

**List A**

the nuclei of two atoms  
joining together

the nucleus of an atom  
splitting into several pieces

an atom losing an electron

an electric charge moving  
through a metal

**List B**

gamma emission

electric current

ionisation

nuclear fission

nuclear fusion

(Total 4 marks)

21

Read this statement from a website.

Immediately after the 'big bang', at the start of the Universe, there were only atoms of the element hydrogen (H).  
Now the Universe contains atoms of over one hundred elements.

(a) Explain how atoms of the element helium (He) are formed in a star.

.....  
.....  
.....  
.....

(2)

(b) Explain how atoms of very heavy elements, such as gold (Au), were formed.

.....

.....

.....

.....

(2)

(c) Explain how, and when, atoms of different elements may be distributed throughout the Universe.

.....

.....

.....

.....

(2)

(Total 6 marks)

22

The table gives information about the three types of particle that make up an atom.

Particle	Relative mass	Relative charge
Proton		+1
Neutron	1	
Electron	very small	-1

(a) Complete the table by adding the **two** missing values.

(2)

(b) Use the information in the table to explain why an atom has no overall electrical charge.

.....

.....

.....

.....

(2)

(c) Uranium has two natural isotopes, uranium-235 and uranium-238.  
Uranium-235 is used as a fuel inside a nuclear reactor.  
Inside the reactor, atoms of uranium-235 are split and energy is released.

(i) How is the structure of an atom of uranium-235 different from the structure of an atom of uranium-238?

.....  
.....

(1)

(ii) The nucleus of a uranium-235 atom must absorb a particle before the atom is able to split.

What type of particle is absorbed?

.....

(1)

(iii) The nucleus of an atom splits into smaller parts in a reactor.

What name is given to this process?

.....

(1)

(Total 7 marks)

23

This passage is from a science magazine.

*A star forms when enough dust and gas are pulled together.  
Masses smaller than a star may also be formed when dust  
and gas are pulled together.*

(a) What is the force which pulls the dust and gas together?

.....

(1)

(b) Complete the sentences.

(i) The smaller masses may be attracted by the star and become

.....

(1)

(ii) Our nearest star, the Sun, is stable because the gravitational forces  
and the radiation pressure are .....

(1)

(iii) The Sun is one of billions of stars in the galaxy called the

.....

(1)  
(Total 4 marks)

24

The diagram shows part of the life cycle of a star which is much bigger than the Sun.

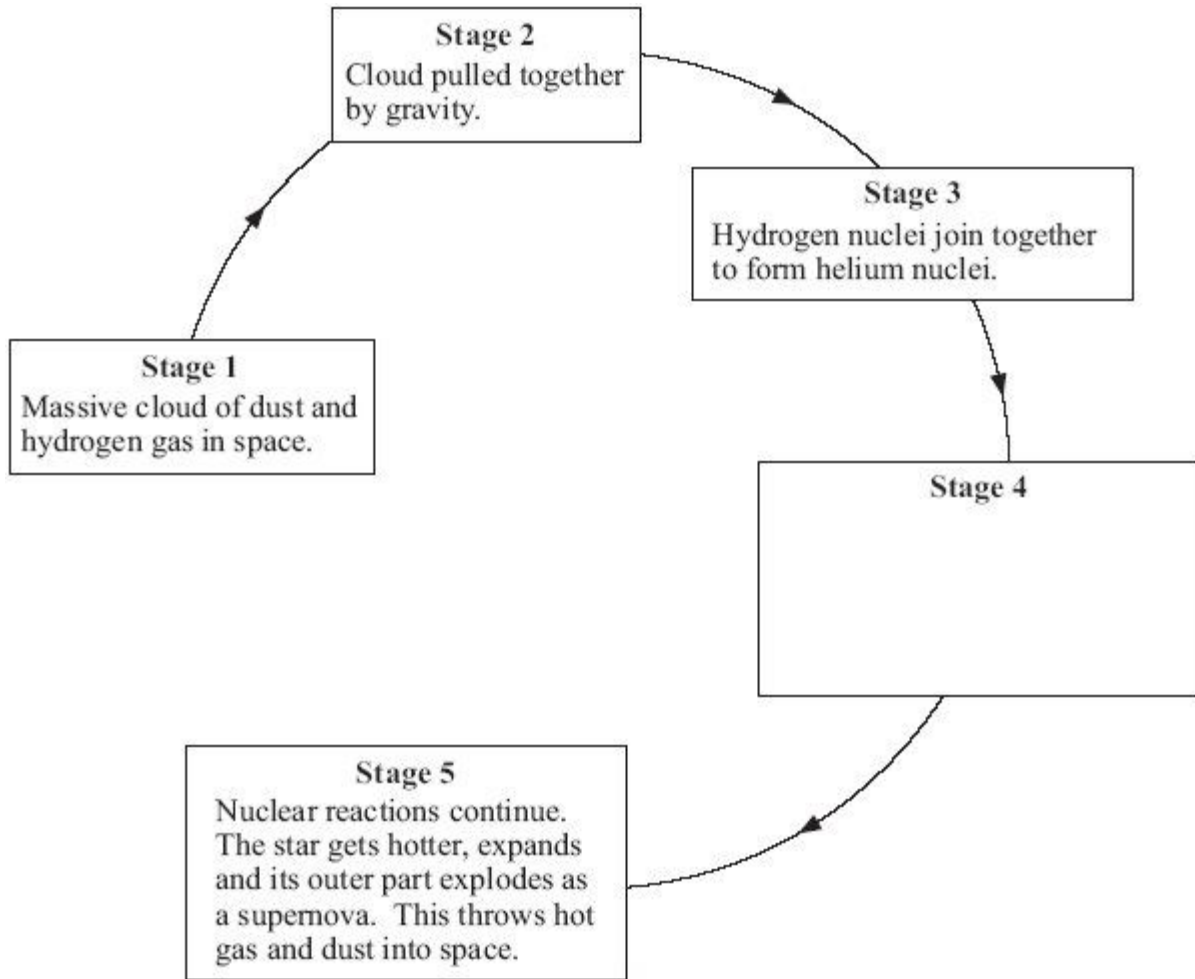

(a) (i) What is the relationship between the masses of the dust and gas in the cloud in **Stage 2** and the force of gravity between them?

.....  
.....

(1)

(ii) What is the relationship between the distance apart of the dust and gas in the cloud in **Stage 2** and the force of gravity between them?

.....  
.....

(1)

(b) In **Stage 3** the star remains stable for millions of years.

Explain why.

.....  
.....  
.....  
.....  
.....

(2)

(c) What happens in **Stage 4**?

.....  
.....  
.....  
.....  
.....

(2)

(Total 6 marks)

25

(a) The diagram shows what can happen when the nucleus of a uranium atom absorbs a neutron.

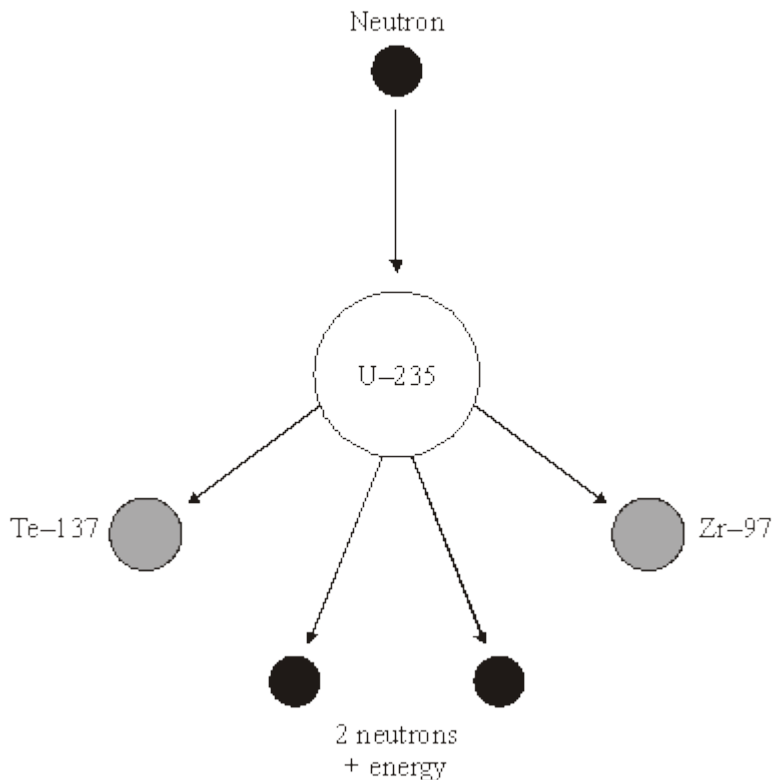

(i) What name is given to the process shown in the diagram?

.....

(1)

(ii) Explain how this process could lead to a chain reaction.

You may wish to add further detail to the diagram to help your answer.

.....  
.....  
.....  
.....

(2)

(iii) How does the mass number of an atom change when its nucleus absorbs a neutron?

.....

(1)

(b) Uranium-235 is used as a fuel in some nuclear reactors.

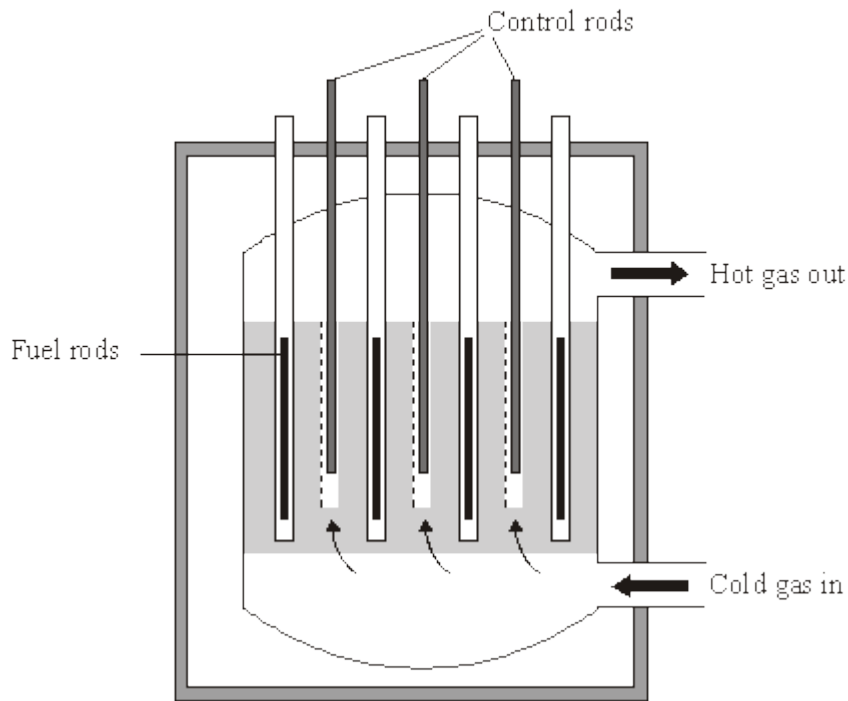

*Source: adapted from 'Physics Matters', by Nick England. Published by Hodder and Stoughton, 1989. Reproduced by permission of Hodder and Stoughton Ltd.*

The reactor contains control rods used to absorb neutrons.

Suggest what happens when the control rods are lowered into the reactor.

.....

.....

.....

.....

(2)  
(Total 6 marks)

26

Read the passage.

In the SolarSystem, the inner planets, such as the Earth, contain elements which are eavierthan the elements hydrogen and helium.

Our star,the Sun, is a medium sized star. If a star is much more massive than the Sunit will eventually swell into a red giant, start to contract, continue tocontract and finally explode.

(a) What is the explosion called?

.....

(1)

(b) Explain why scientists believe that the Solar System was formed from the material produced when earlier stars exploded.

.....  
.....  
.....  
.....  
.....  
.....

(3)

(Total 4 marks)

27

(a) Complete the **two** spaces in the sentence.

Stars form when enough ..... and gas from ..... are pulled together by gravitational attraction.

(2)



(b) How are stars able to give out energy for millions of years?

Put a tick (✓) next to the answer.

By atoms joining together

By atoms splitting apart

By burning gases

(1)

(c) There are many billions of stars in our galaxy. Our Sun is one of these stars. What is the name of our galaxy?

.....

(1)

(d)

**Why was the Universe created?**

We cannot expect scientists to answer this question. What is the reason for this?

Put a tick (✓) next to the reason.

It will take too long to collect the scientific evidence.

The answer depends on beliefs and opinions, not scientific evidence.

There is not enough scientific evidence.

(1)

**(Total 5 marks)**

**28**

The statement in the box is from an article in a science magazine.

Scientists think that all the elements on Earth are also present throughout the Universe.

(a) (i) Name the process by which these elements were formed.

.....

(1)

(ii) Where did the elements form?

.....

(1)

(iii) What caused these elements to be distributed throughout the Universe?

.....

(1)

(b) Scientists have only examined a tiny fraction of the Universe. What is the basis for the statement in the science magazine?

.....

.....

(1)

(Total 4 marks)

**29**

To gain full marks in this question you should write your ideas in good English. Put them into a sensible order and use the correct scientific words.

Explain briefly how stars like the Sun are thought to have been formed.

.....

.....

.....

.....

(Total 2 marks)

**30**

(a) Nuclear power stations use the energy released by *nuclear fission* to generate electricity.

(i) Explain what is meant by *nuclear fission*.

.....

.....

.....

(2)

(ii) How does nuclear fission lead to a chain reaction?

You may give your answer as a labelled diagram.

.....  
.....

(1)

(b) Although nuclear fuels are relatively cheap the total cost of generating electricity using nuclear fuels is expensive. Why?

.....  
.....

(1)

(c) The table compares the energy released from 1 kg of coal and 1 kg of uranium.

Coal	29 MJ
Uranium	580 000 MJ

1 MJ = 1 000 000 joules

State **one** benefit to the environment of using a concentrated fuel like uranium to generate electricity rather than using the energy from coal.

.....  
.....

(1)

(Total 5 marks)

31

(a) Explain how stars produce energy.

.....  
.....  
.....  
.....

(2)

- (b) What evidence is there to suggest that the Sun was formed from the material produced when an earlier star exploded?

.....  
 .....

(1)

- (c) It is thought that gases from the massive star Cygnus X-1 are spiralling into a black hole.

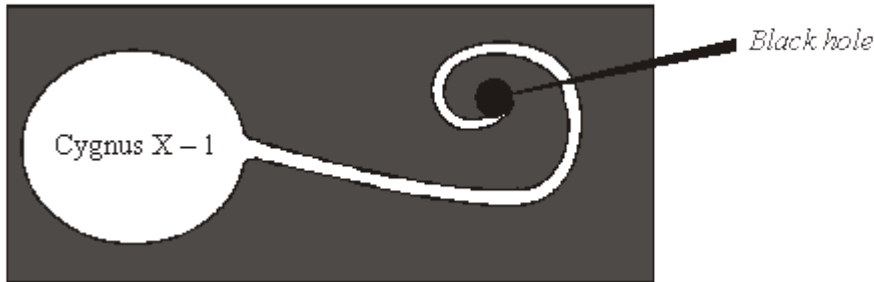

- (i) Explain what is meant by the term *black hole*.

.....  
 .....

(2)

- (ii) What is produced as the gases from a star spiral into a black hole?

.....

(1)

(Total 6 marks)

32

- (a) Uranium-234 ( $^{234}\text{U}$ ) is a radioactive element. The graph shows the number of protons and neutrons in the nuclei of the elements formed when uranium-234 decays.

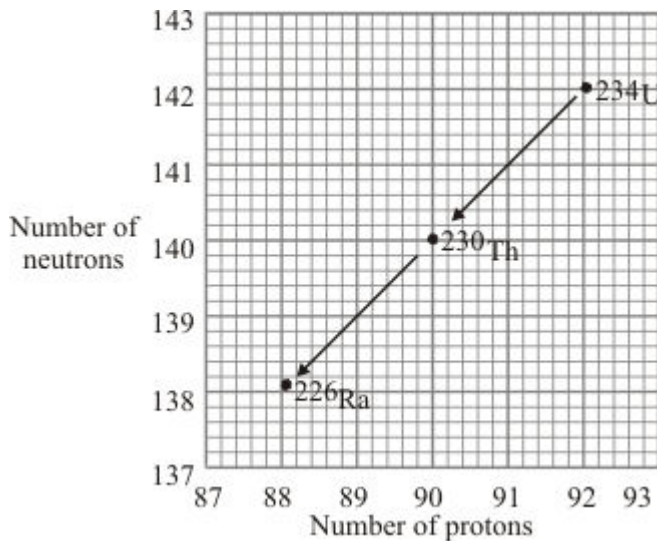

- (i) How does the graph show that uranium-234 ( $^{234}\text{U}$ ) and thorium-230 ( $^{230}\text{Th}$ ) emit alpha particles?

.....

(1)

- (ii) What makes uranium and thorium different elements?

.....

(1)

- (iii) Radioactive decay may also produce gamma radiation.

Why does the emission of gamma radiation **not** cause a new element to be formed?

.....

.....

(1)

- (b) The graph shows how the thickness of different materials needed to absorb 90% of the gamma radiation emitted by a source depends on the energy of the radiation. The energy of the gamma radiation is given in units called electron-volts.

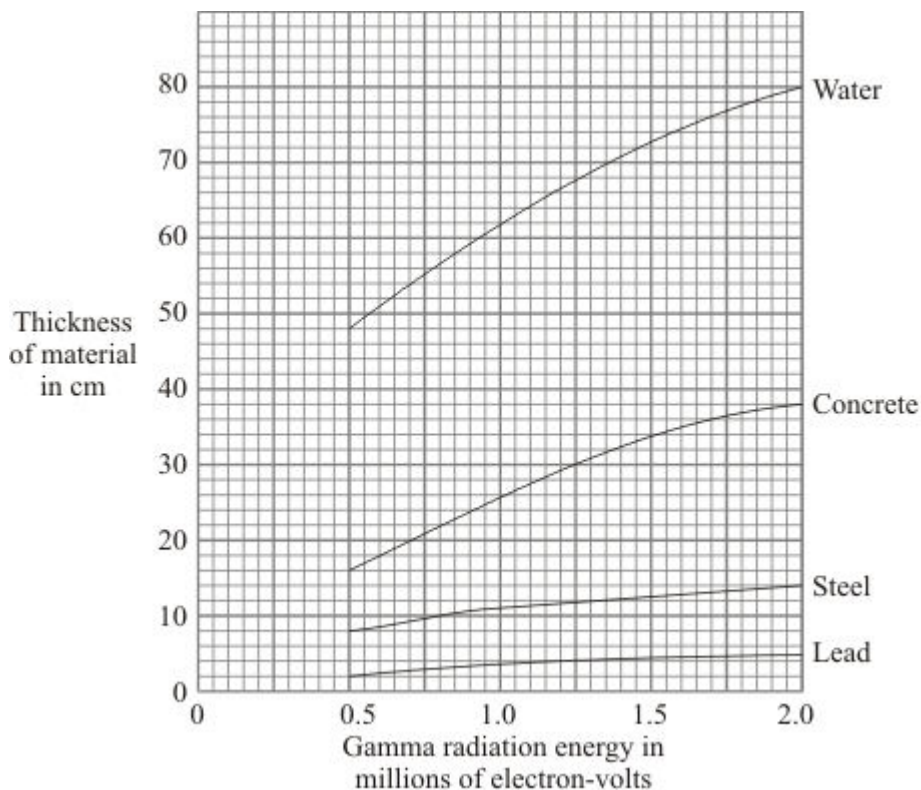

- (i) Which of the materials shown is least effective at absorbing gamma radiation? Use the information in the graph to give a reason for your answer.

.....

.....

(1)

- (ii) For gamma radiation of energy 1.5 million electron-volts, how many times more effective is steel than water at absorbing the radiation? Show clearly how you obtain your answer.

.....

.....

.....

(2)

- (c) Scientists in the early twentieth century thought that atoms were made up of electrons scattered inside a ball of positive charge. This was called the 'plum-pudding' model of the atom.

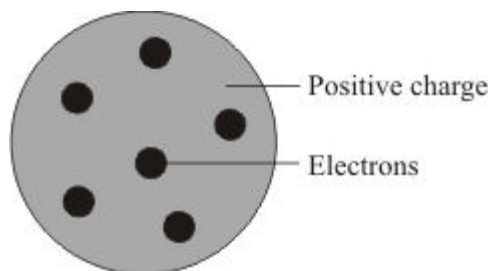

**Plum pudding model**

Rutherford and Marsden did an experiment, in which a beam of alpha particles was aimed at a thin sheet of gold.

Explain how the results of this experiment led to a new model of the atom.

You may include one or more diagrams in your answer.

.....

.....

.....

.....

.....

.....

(3)  
(Total 9 marks)

33

(a) Most of the Sun is hydrogen. Inside the core of the sun, hydrogen is being converted to helium. What name is given to this process and why is the process so important?

.....

.....

.....

(2)

(c) Describe what will happen to the Sun as the core runs out of hydrogen.

.....

.....

.....

.....

.....

(3)  
(Total 5 marks)

34

The first commercial nuclear power station in the world was built at Calder Hall in Cumbria.

(a) The fuel used at the Calder Hall power station is uranium. Natural uranium consists mainly of two isotopes: uranium-235 ( ${}_{92}^{235}\text{U}$ ) and uranium-238 ( ${}_{92}^{238}\text{U}$ ). The nucleus of a uranium-235 atom is different to that of a uranium-238 atom.

(i) Where is the nucleus in an atom?

.....

(1)

(ii) Name the **two** types of particle found in the nucleus.

..... and .....

(2)

(iii) How is the nucleus of a uranium-238 atom different to the nucleus of a uranium-235 atom?

.....

.....

.....

(2)

(b) In the nuclear reactor fission of uranium atoms takes place in reactions such as the one shown below.



The nuclear reactions are carefully controlled in the power station so that a chain reaction takes place.



Explain, as fully as you can:

- (i) how fission of uranium atoms takes place in a nuclear reactor;

.....  
.....  
.....  
.....

- (ii) how this leads to a chain reaction;

.....  
.....  
.....  
.....

- (iii) why it can be used to generate electricity.

.....  
.....

(4)  
(Total 9 marks)

35

The first commercial nuclear power station in the world was built at Calder Hall in Cumbria.

The atoms produced by the fission of uranium are also radioactive. The used fuel is sent to a reprocessing plant where it can be safely treated.

- (i) Calder Hall power station is next to the Sellafield reprocessing plant. Suggest an advantage of having the two plants close together.

.....  
.....

(1)

- (ii) One of the radioactive products is iodine-138. This has a half-life of 6 seconds. A sample of radioactive material contains 2000 atoms of iodine-138. How long will it take for the number of iodine-131 atoms to decrease to 125?

.....

.....

.....

.....

Answer = ..... seconds

(3)  
(Total 4 marks)

**36**

Nuclear fusion in the Sun releases large amounts of energy.

- (i) Explain what is meant by nuclear fusion.

.....

.....

.....

.....

.....

(3)

- (ii) Why is energy released by such nuclear fusion reactions?

.....

.....

.....

.....

(2)  
(Total 5 marks)

**37**

(a) The Sun is at the stable stage of its life.

Explain, in terms of the forces acting on the Sun, what this means.

.....

.....

.....

.....

.....

.....

**(3)**

(b) At the end of the stable stage of its life a star will change.

Describe and explain the changes that could take place.

.....

.....

.....

.....

.....

.....

**(6)**  
**(Total 9 marks)**

**38**

Our Sun is just one of many millions of stars in a galaxy called the Milky Way.

Our Sun is in the main stable period of a star's lifetime. The massive force of gravity draws its matter together. This force is balanced by the very high temperatures, from the fusion of hydrogen atoms, which tend to make the Sun expand. Describe and explain what will happen to the Sun as the hydrogen is eventually used up.

.....

.....

.....

.....

.....

.....

**(Total 3 marks)**

**39**

Studying stars gives scientists evidence about the evolution of the Universe.

(a) (i) In astronomy, what is meant by a black hole?

.....

.....

.....

.....

**(2)**

(ii) How is it possible to detect a black hole?

.....

.....

.....

.....

**(2)**

(b) The changes which happen in stars result in new elements being formed.

Nuclei of the heaviest elements are found in the Sun.

Describe how these nuclei are formed.

.....

.....

.....

.....

**(2)**  
**(Total 6 marks)**



41

The Sun at the centre of our solar system is a star.

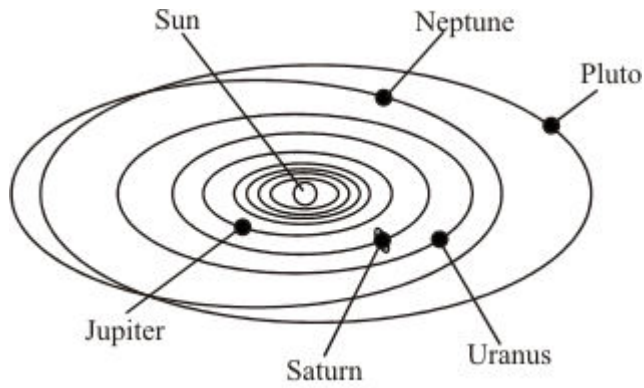

- (a) The Sun contains nuclei of the heaviest elements. Atoms of these heaviest elements are also present in the planets of the solar system. What does this suggest about the material from which the solar system is formed?

.....

.....

.....

(1)





42

The flowchart shows four stages thought to occur in the evolution of a star such as our Sun.

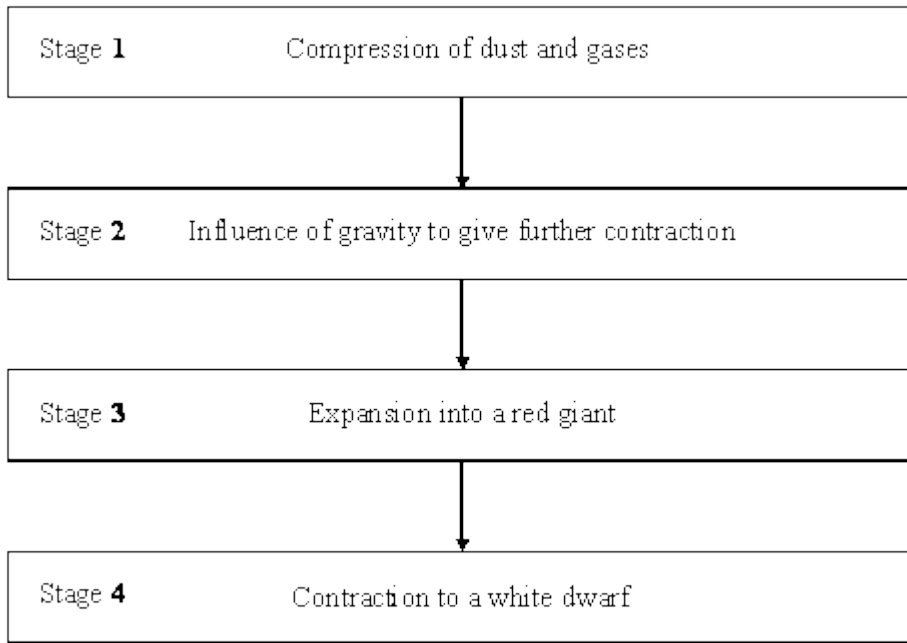

At a particular time a star might have reached one of these stages or be between stages or be at a further stage. What period in its evolution has our star, the Sun, reached?

.....

(Total 1 mark)

43

At the very high temperatures in the sun, hydrogen is converted into helium. It takes four hydrogen nuclei to produce one helium nucleus.

The table shows the relative masses of hydrogen and helium nuclei.



Hydrogen  
nucleus



Helium  
nucleus

Nucleus	Relative Mass
hydrogen	1.007825
helium	4.0037

(a) Use these figures to calculate what happens to the mass of the sun as hydrogen is converted to helium.

.....

.....

.....

.....

(3)

- (b) Use your answer to part (a) to explain how the sun has been able to radiate huge amounts of energy for billions of years.

.....

.....

.....

(2)  
(Total 5 marks)

44

The energy radiated by a **main sequence** star like the Sun is released by a nuclear fusion reaction in its core.

Read the following information about this reaction then use it to answer the questions below.

- The net result of the nuclear fusion reaction is that four hydrogen nuclei produce one helium nucleus. There is a loss of mass of 0.7%.
- For nuclear fusion to occur nuclei must collide at very high speeds.
- The energy released during the reaction can be calculated as shown:

$$\text{energy released [J]} = \text{loss of mass [kg]} \times (\text{speed of light [m/s}^2\text{)})$$

(The speed of light is  $3 \times 10^8$  m/s)

- (a) Calculate the energy released when 1g of hydrogen fuses to form helium.

(Show your working.)

.....

.....

.....

.....

.....

.....

(4)

- (b) The table shows the lifetimes and surface temperatures of main sequence stars with different masses.

MASS OF STAR [SUN = 1]	LIFETIME ON MAIN SEQUENCE [MILLION OF YEARS]	SURFACE TEMPERATURE * [KELVIN]
0.5	200 000	4000
1	10 000	6000
3	500	11 000
15	15	30 000

[\* The higher the surface temperature of a star, the higher the temperature and pressure in its core.]

- (i) Describe the relationship between the lifetime of a main sequence star and its mass.

.....  
 .....  
 .....

(2)

- (ii) Suggest an explanation for this relationship.

.....  
 .....  
 .....  
 .....  
 .....

(3)

(Total 9 marks)

45

Describe, in as much detail as you can, the life history of a star like our Sun.

.....

.....

.....

.....

.....

.....

.....

.....

.....

.....

.....

.....

.....

.....

.....

.....

**(Total 6 marks)**