

1

A student investigated the reaction of copper carbonate with dilute sulfuric acid.

The student used the apparatus shown in the figure below.

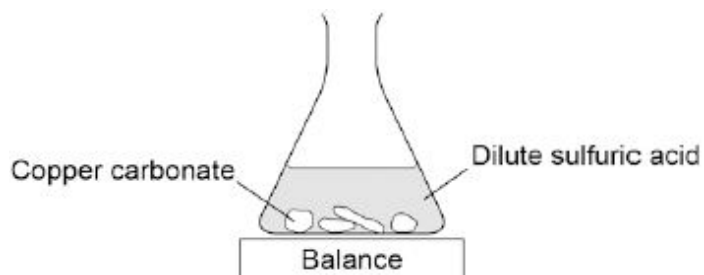

(a) Complete the state symbols in the equation.

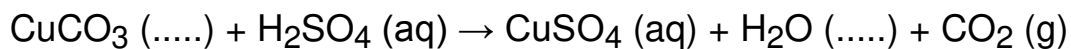

(2)

(b) Why did the balance reading decrease during the reaction?

Tick **one** box.

The copper carbonate broke down.

A salt was produced in the reaction.

A gas was lost from the flask.

Water was produced in the reaction.

(1)

- (b) The structure of potassium sulfide can be represented using the ball and stick model in **Figure 2**.

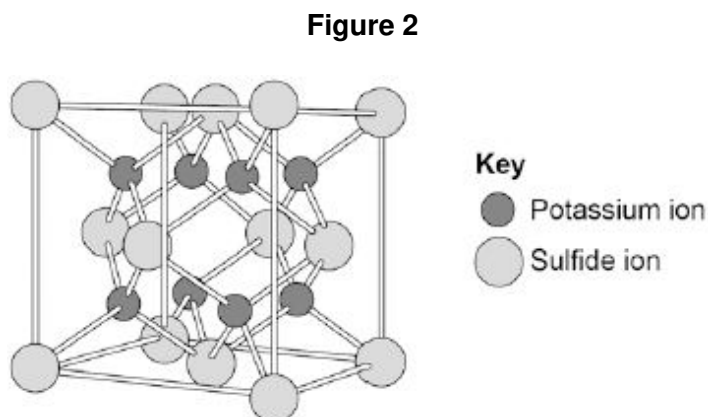

The ball and stick model is **not** a true representation of the structure of potassium sulfide.

Give **one** reason why.

.....

.....

(1)

- (c) Sulfur can also form covalent bonds.

Complete the dot and cross diagram to show the covalent bonding in a molecule of hydrogen sulfide.

Show the outer shell electrons only.

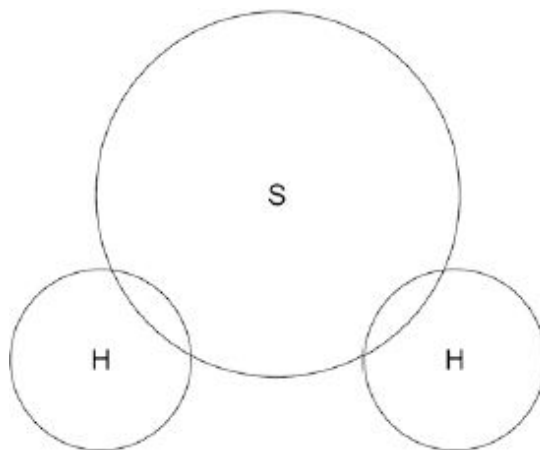

(2)

(d) Calculate the relative formula mass (M_r) of aluminium sulfate $\text{Al}_2(\text{SO}_4)_3$

Relative atomic masses (A_r): oxygen = 16; aluminium = 27; sulfur = 32

.....
.....
.....

Relative formula mass =

(2)

- (e) Covalent compounds such as hydrogen sulfide have low melting points and do **not** conduct electricity when molten.

Draw **one** line from each property to the explanation of the property.

Property	Explanation of property
Low melting point	Electrons are free to move
Low melting point	There are no charged particles free to move
Low melting point	Ions are free to move
Does not conduct electricity when molten	Weak intermolecular forces of attraction
Does not conduct electricity when molten	Bonds are weak
Does not conduct electricity when molten	Bonds are strong

(2)

- (f) Ionic compounds such as potassium sulfide have high boiling points and conduct electricity when dissolved in water.

Draw **one** line from each property to the explanation of the property.

Property	Explanation of property
High boiling point	Electrons are free to move
	There are no charged particles free to move
	Ions are free to move
	Weak intermolecular forces of attraction
Conduct electricity when molten	Bonds are weak
	Bonds are strong

(2)
(Total 14 marks)

3

This question is about halogens and their compounds.

The table below shows the boiling points and properties of some of the elements in Group 7 of the periodic table.

Element	Boiling point in °C	Colour in aqueous solution
Fluorine	-188	colourless
Chlorine	-35	pale green
Bromine	X	orange
Iodine	184	brown

(a) Why does iodine have a higher boiling point than chlorine?

Tick **one** box.

Iodine is ionic and chlorine is covalent

Iodine is less reactive than chlorine

The covalent bonds between iodine atoms are stronger

The forces between iodine molecules are stronger

(1)

(b) Predict the boiling point of bromine.

.....

(1)

- (c) A redox reaction takes place when aqueous chlorine is added to potassium iodide solution.

The equation for this reaction is:

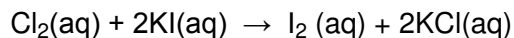

Look at table above.

What is the colour of the final solution in this reaction?

Tick **one** box.

Brown

Orange

Pale green

Colourless

(1)

- (d) What is the ionic equation for the reaction of chlorine with potassium iodide?

Tick **one** box.

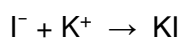
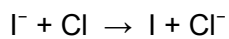
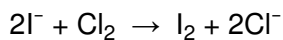
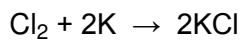

(1)

(e) Why does potassium iodide solution conduct electricity?

Tick **one** box.

It contains a metal

It contains electrons which can move

It contains ions which can move

It contains water

(1)

(f) What are the products of electrolysis of potassium iodide solution?

Tick **one** box.

Product at cathode

Product at anode

hydrogen

iodine

hydrogen

oxygen

potassium

iodine

potassium

oxygen

(1)

(Total 6 marks)

4 Gold is mixed with other metals to make jewellery.

The figure below shows the composition of different carat values of gold.

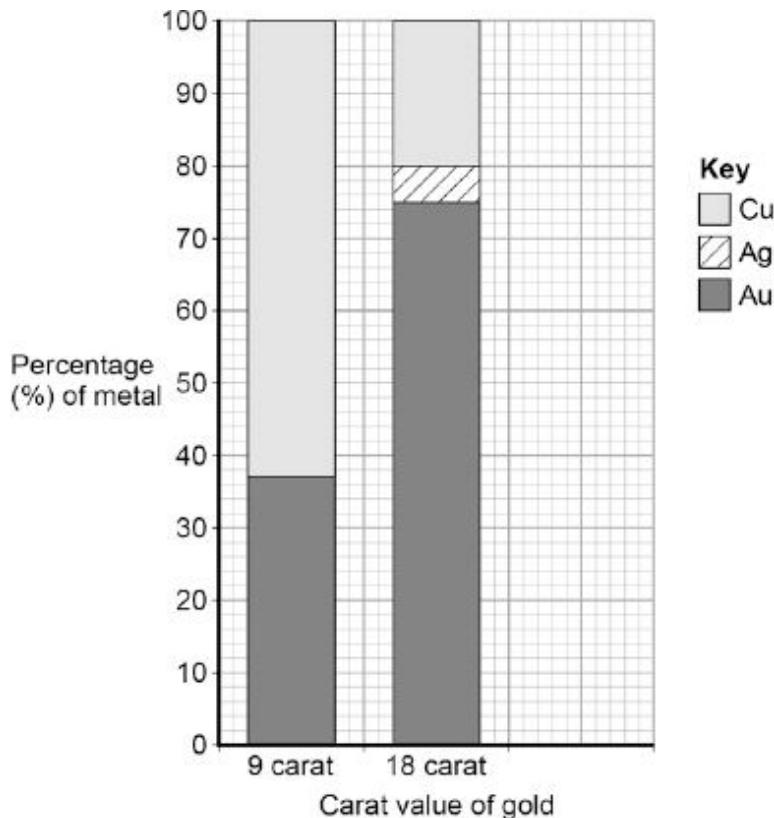

(a) What is the percentage of gold in 12 carat gold?

Tick **one** box.

12 % 30 % 50 % 80 %

(1)

(b) Give the percentage of silver in 18 carat gold.

Use the figure above to answer this question.

Percentage = %

(1)

(c) Suggest **two** reasons why 9 carat gold is often used instead of pure gold to make jewellery.

1

.....

2

.....

(2)
(Total 4 marks)

5

The table below gives information about four alcohols.

Alcohol	Formula	Melting point in °C	Boiling point in °C
Methanol	CH ₃ OH	-94	65
Ethanol	CH ₃ CH ₂ OH	-118	78
Propanol	CH ₃ CH ₂ CH ₂ OH	-129	97
Butanol	CH ₃ CH ₂ CH ₂ CH ₂ OH	-89	118

(a) Which alcohol in the table is liquid over the greatest temperature range?

.....

(1)

(b) Which statement is correct?

Tick **one** box.

A molecule of ethanol has 5 hydrogen atoms

Butanol has the highest boiling point

Methanol has the largest molecules

Propanol has the highest melting point

(1)

(c) A molecule of methanol has five single covalent bonds.

Draw the missing bonds in **Figure 1** to complete the displayed formula for methanol.

Figure 1

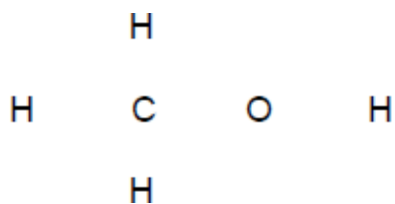

(1)

(d) **Figure 2** shows a flow diagram of the process to produce ethanol.

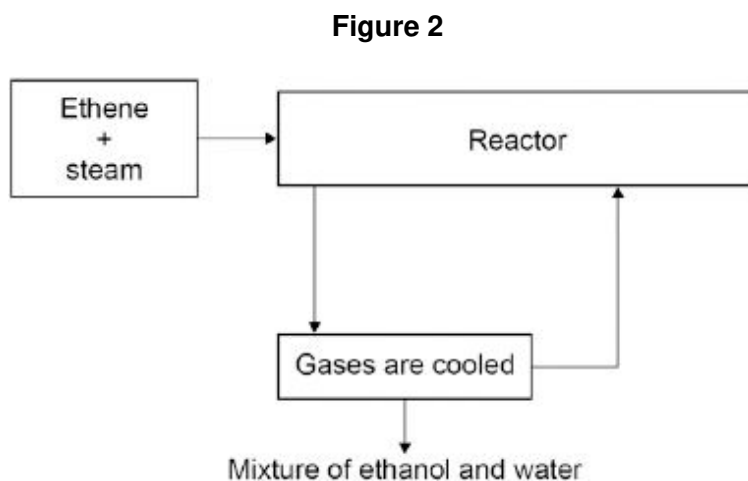

Complete the word equation for the reaction to produce ethanol.

..... + → ethanol

(1)

(e) What happens to the unreacted ethene?

.....

(1)

(f) Wine contains ethanol.
 A bottle of wine was left open in air.
 After a few days, the wine tasted of vinegar.
 Vinegar is a solution of ethanoic acid in water.

Explain how oxidation causes the wine to taste of vinegar after a few days.

.....

(3)
(Total 8 marks)

6

In industry ethanol is produced by the reaction of ethene and steam at 300°C and 60 atmospheres pressure using a catalyst.

The equation for the reaction is:

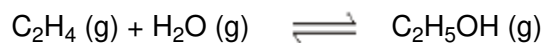

The figure below shows a flow diagram of the process.

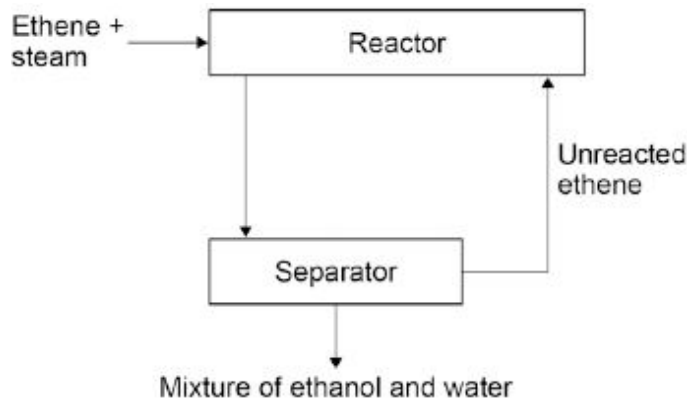

- (a) Why does the mixture from the separator contain ethanol and water?

.....

(1)

- (b) The forward reaction is exothermic.

Use Le Chatelier's Principle to predict the effect of increasing temperature on the amount of ethanol produced at equilibrium.

Give a reason for your prediction.

.....

(2)

- (c) Explain how increasing the pressure of the reactants will affect the amount of ethanol produced at equilibrium.

.....

.....

.....

.....

(2)
(Total 5 marks)

7

The structures of four substances, **A**, **B**, **C** and **D**, are represented in **Figure 1**.

Figure 1

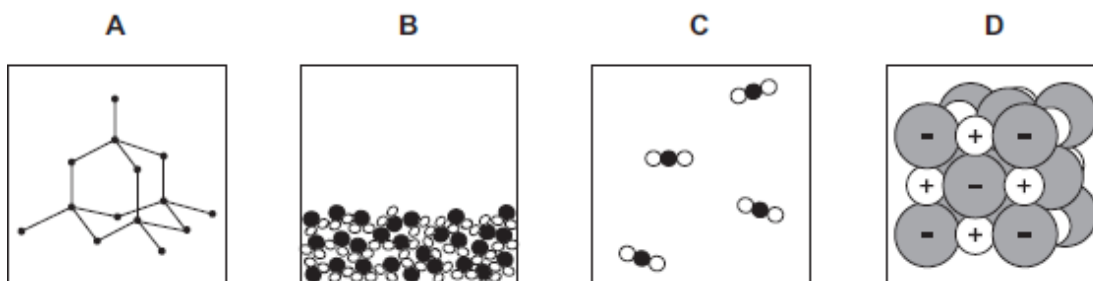

- (a) Use the correct letter, **A**, **B**, **C** or **D**, to answer each question.

(i) Which substance is a gas?

(1)

(ii) Which substance is a liquid?

(1)

(iii) Which substance is an element?

(1)

(iv) Which substance is made of ions?

(1)

- (b) **Figure 2** shows the bonding in substance **C**.

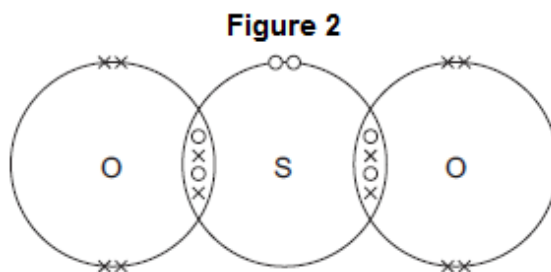

- (i) What is the formula of substance **C**?

Draw a ring around the correct answer.

SO₂

SO²

S₂O

(1)

- (ii) Use the correct answer from the box to complete the sentence.

delocalised	shared	transferred
--------------------	---------------	--------------------

When a sulfur atom and an oxygen atom bond to produce substance **C**,
electrons are

(1)

- (iii) What is the type of bonding in substance **C**?

Draw a ring around the correct answer.

covalent

ionic

metallic

(1)

(Total 7 marks)

8

This question is about copper.

- (a) Copper can be extracted by smelting copper-rich ores in a furnace.

The equation for one of the reactions in the smelting process is:



Explain why there would be an environmental problem if sulfur dioxide gas escaped into the atmosphere.

.....

.....

.....

.....

(2)

(b) The impure copper produced by smelting is purified by electrolysis, as shown below.

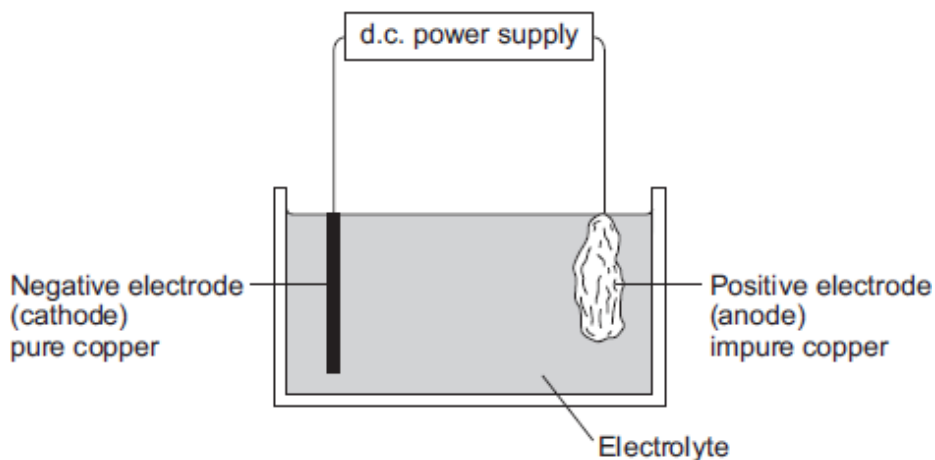

Copper atoms are oxidised at the positive electrode to Cu^{2+} ions, as shown in the half equation.



(i) How does the half equation show that copper atoms are oxidised?

.....

(1)

(ii) The Cu^{2+} ions are attracted to the negative electrode, where they are reduced to produce copper atoms.

Write a balanced half equation for the reaction at the negative electrode.

.....

(1)

(iii) Suggest a suitable electrolyte for the electrolysis.

.....

(1)

(c) Copper metal is used in electrical appliances.

Describe the bonding in a metal, and explain why metals conduct electricity.

.....

.....

.....

.....

.....

.....

.....

.....

.....

.....

(4)

(d) Soil near copper mines is often contaminated with low percentages of copper compounds.

Phytomining is a new way to extract copper compounds from soil.

Describe how copper compounds are extracted by phytomining.

.....

.....

.....

.....

.....

.....

.....

(3)

(e) A compound in a copper ore has the following percentage composition by mass:

55.6% copper, 16.4% iron, 28.0% sulfur.

Calculate the empirical formula of the compound.

Relative atomic masses (A_r): S = 32; Fe = 56; Cu = 63.5

You must show all of your working.

.....

.....

.....

.....

.....

.....

.....

.....

.....

Empirical formula =

(4)
(Total 16 marks)

9

This question is about ethanol.

(a) Ethanol is produced by the reaction of ethene and steam:



(i) **Figure 1** shows the energy level diagram for the reaction.

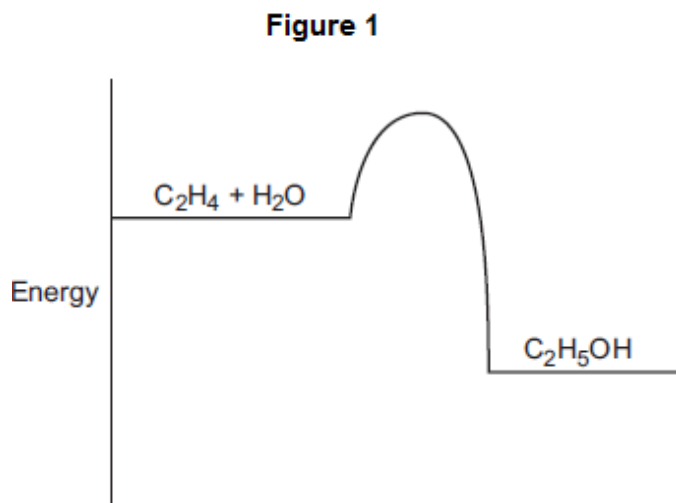

How does the energy level diagram show that the reaction is exothermic?

.....

(1)

(ii) A catalyst is used for the reaction.

Explain how a catalyst increases the rate of the reaction.

.....

(2)

(b) **Figure 2** shows the displayed structure of ethanol.

Figure 2

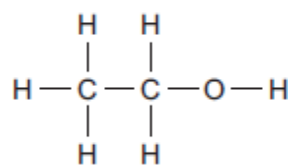

Complete the dot and cross diagram in **Figure 3** to show the bonding in ethanol.

Show the outer shell electrons only.

Figure 3

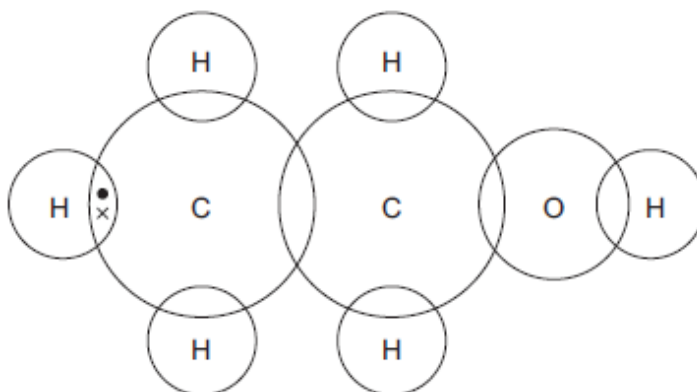

(2)

- (c) A student burned some ethanol.

Figure 4 shows the apparatus the student used.

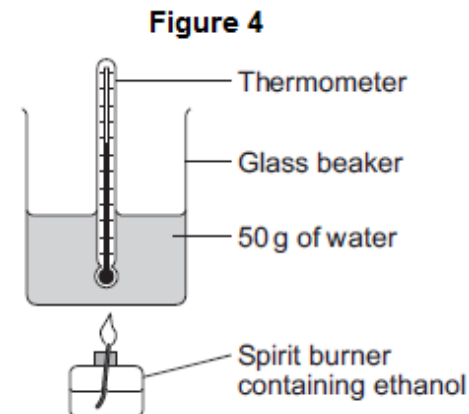

- (i) The student recorded the temperature of the water before and after heating.

His results are shown in **Table 1**.

Table 1

Temperature before heating	20.7 °C
Temperature after heating	35.1 °C

Calculate the energy used to heat the water.

Use the equation $Q = m \times c \times \Delta T$

The specific heat capacity of water = 4.2 J / g / °C

.....

.....

.....

.....

.....

Energy used = J

(3)

- (ii) **Table 2** shows the mass of the spirit burner before the ethanol was burned and after the ethanol was burned.

Table 2

Mass of spirit burner before ethanol was burned	72.80 g
Mass of spirit burner after ethanol was burned	72.10 g

Calculate the number of moles of ethanol (C_2H_5OH) that were burned.

Relative atomic masses (A_r): H = 1; C = 12; O = 16

.....

.....

.....

.....

.....

Number of moles burned =

(3)

- (iii) Calculate the energy released in joules per mole.

You should assume that all the energy from the ethanol burning was used to heat the water.

.....

Energy = J / mole

(1)

- (d) The names, structures and boiling points of ethanol and two other alcohols are shown in

Table 3.**Table 3**

Name	Methanol	Ethanol	Propanol
Structure	$\begin{array}{c} \text{H} \\ \\ \text{H}-\text{C}-\text{O}-\text{H} \\ \\ \text{H} \end{array}$	$\begin{array}{c} \text{H} \quad \text{H} \\ \quad \\ \text{H}-\text{C}-\text{C}-\text{O}-\text{H} \\ \quad \\ \text{H} \quad \text{H} \end{array}$	$\begin{array}{c} \text{H} \quad \text{H} \quad \text{H} \\ \quad \quad \\ \text{H}-\text{C}-\text{C}-\text{C}-\text{O}-\text{H} \\ \quad \quad \\ \text{H} \quad \text{H} \quad \text{H} \end{array}$
Boiling point in °C	65	78	97

Use your knowledge of structure and bonding to suggest why the boiling points increase as the number of carbon atoms increases.

.....

.....

.....

.....

.....

.....

.....

.....

(3)
(Total 15 marks)

10

This question is about salts.

- (a) Salt (sodium chloride) is added to many types of food.

Sodium chloride is produced by reacting sodium with chlorine.



The diagram shows what happens to atoms of sodium and chlorine in this reaction.

The dots (•) and crosses (×) represent electrons.

Only the outer electrons are shown.

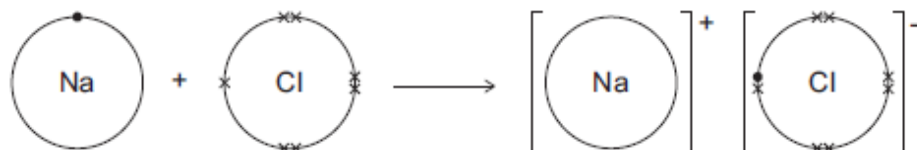

Describe, in terms of electrons, what happens when a sodium atom reacts with a chlorine atom to produce sodium chloride.

.....

.....

.....

.....

.....

.....

(3)

(b) Lack of iodine can affect the learning ability of children.

One idea is that salt (sodium chloride) should have iodine added.

(i) Iodine consists of simple molecules.

What is a property of substances that have simple molecules?

Tick (✓) **one** box.

Have no overall electric charge

Have high boiling points

Have giant covalent structures

(1)

(ii) Which one of the following questions cannot be answered by science alone?

Tick (✓) **one** box.

How much sodium chloride is in food?

What harm does a lack of iodine do?

Should iodine be added to salt in food?

Give **one** reason why this question cannot be answered by science alone.

.....
.....

(2)

(c) A student produced the salt ammonium nitrate by adding an acid to ammonia solution.

(i) Name the acid used.

.....

(1)

(ii) Use the correct answer from the box to complete the sentence.

an acid

an alkali

a salt

Ammonia solution (ammonium hydroxide) is

(1)

(iii) The student added a few drops of a solution which changed colour when the reaction was complete.

Complete the sentence.

The solution added is an

(1)

(d) Farmers buy solid ammonium nitrate in poly(ethene) sacks.

(i) How is solid ammonium nitrate made from a solution of ammonium nitrate?

Tick (✓) **one** box.

Crystallisation

Decomposition

Electrolysis

(1)

- (ii) Why do farmers use ammonium nitrate on their fields?

.....

(1)

- (iii) The properties of poly(ethene) depend on the reaction conditions when it is made.

State **one** reaction condition that can be changed when making poly(ethene).

.....

(1)

(Total 12 marks)**11**

This question is about electrolysis.

- (a) Metal spoons can be coated with silver.
 This is called electroplating.

Suggest **one** reason why spoons are electroplated.

.....

(1)

- (b) When sodium chloride solution is electrolysed the products are hydrogen and chlorine.

- (i) What is made from chlorine?

Tick (✓) **one** box.

Bleach

Fertiliser

Soap

(1)

- (ii) Sodium chloride solution contains two types of positive ions, hydrogen ions (H^+) and sodium ions (Na^+).

Why is hydrogen produced at the negative electrode and **not** sodium?

Tick (✓) **one** box.

Hydrogen is a gas.

Hydrogen is less reactive than sodium.

Hydrogen ions move faster than sodium ions.

(1)

- (iii) Hydrogen and chlorine can be used to produce hydrogen chloride.

The diagrams in **Figure 1** show how the outer electrons are arranged in an atom of hydrogen and an atom of chlorine.

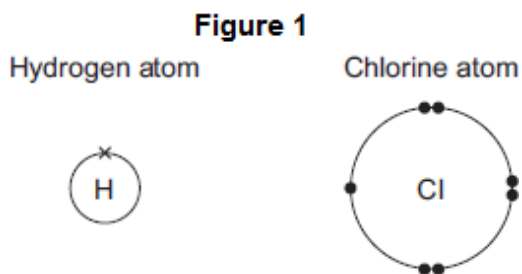

Complete **Figure 2** to show how the outer electrons are arranged in a molecule of hydrogen chloride (HCl).

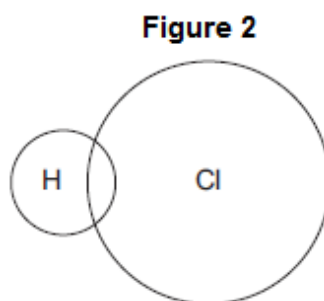

(1)

(iv) What is the type of bond in a molecule of hydrogen chloride?

Tick (✓) **one** box.

Covalent

Ionic

Metallic

(1)

(v) Why is hydrogen chloride a gas at room temperature (20 °C)?

Tick (✓) **two** boxes.

Hydrogen chloride has a low boiling point.

Hydrogen chloride has a high melting point.

Hydrogen chloride is made of simple molecules.

Hydrogen chloride does not conduct electricity.

Hydrogen chloride has a giant structure.

(2)

- (c) Aluminium is produced by electrolysis of a molten mixture of aluminium oxide and cryolite. This is shown in **Figure 3**.

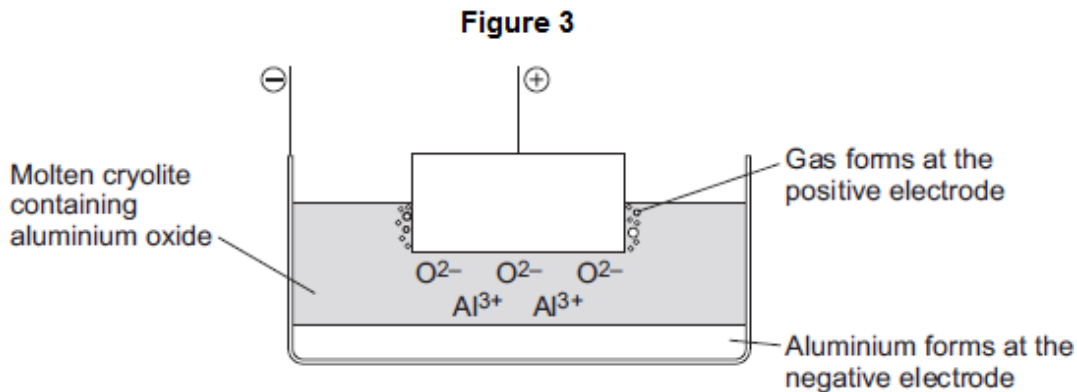

- (i) Name a gas produced at the positive electrode.

.....

(1)

- (ii) Aluminium ions move to the negative electrode.

Explain why.

.....

(2)

- (iii) At the negative electrode, the aluminium ions gain electrons to produce aluminium.

What is this type of reaction called?

Tick (✓) **one** box.

- | | |
|------------|--------------------------|
| Combustion | <input type="checkbox"/> |
| Oxidation | <input type="checkbox"/> |
| Reduction | <input type="checkbox"/> |

(1)

(iv) Aluminium has layers of atoms, as shown in **Figure 4**.

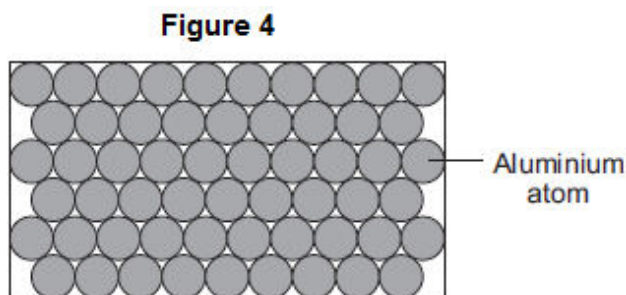

Complete the sentence.

Metals can be bent and shaped because the layers of atoms can

(1)

(d) Electrodes used in the production of aluminium are made from graphite.

(i) Which diagram, **A**, **B** or **C**, shows the structure of graphite?

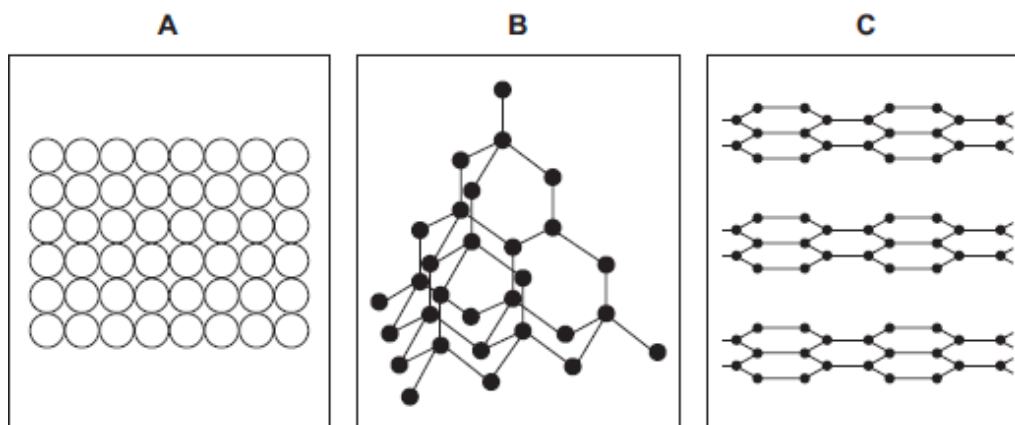

The structure of graphite is shown in diagram

(1)

(ii) The temperature for the electrolysis is 950 °C.

Use the correct answer from the box to complete the sentence.

cross links	a giant ionic lattice	strong covalent bonds
--------------------	------------------------------	------------------------------

The graphite does not melt at 950 °C because

graphite has

(1)

(Total 14 marks)

12

This question is about metals and alloys.

(a) Explain how electricity is conducted in a metal.

To gain full marks you must include a description of the structure and bonding of a metal.

.....

.....

.....

.....

.....

.....

.....

.....

(4)

(b) Describe how the structure of an alloy is different from the structure of a pure metal.

.....

.....

.....

.....

(2)

(c) Alloys are used to make dental braces and coins.

(i) Nitinol is an alloy used in dental braces.

Why is Nitinol used in dental braces?

.....
.....

(1)

(ii) Suggest **one** reason why coins are not made of pure copper.

Do **not** give cost as a reason.

.....
.....

(1)

(iii) Some coins are made from an alloy of aluminium.

Complete the sentence.

Aluminium is manufactured by the electrolysis of a molten mixture of cryolite and

.....

(1)

(iv) Banks keep coins in poly(ethene) bags. These bags are made from low density poly(ethene).

High density poly(ethene) can also be made from the same monomer.

How can the same reaction produce two different products?

.....
.....

(1)

(d) Give **two** reasons why instrumental methods of analysis are used to detect impurities in metals.

.....
.....
.....

(1)

(Total 11 marks)

13

This question is about compounds.

(a) The table gives information about the solubility of some compounds.

Soluble compounds
All potassium and sodium salts
All nitrates
Chlorides, bromides and iodides, except those of silver and lead

Use information from the table to answer these questions.

(i) Name a soluble compound that contains silver ions.

.....

(1)

(ii) Name a soluble compound that contains carbonate ions.

.....

(1)

(b) Metal oxides react with acids to make salts.

What type of compound is a metal oxide?

.....

(1)

(c) Lead nitrate solution is produced by reacting lead oxide with nitric acid.

(i) State how solid lead nitrate can be obtained from lead nitrate solution.

.....

.....

(1)

(ii) Balance the equation for the reaction.

**(1)**(iii) Give the total number of atoms in the formula $\text{Pb}(\text{NO}_3)_2$

.....

(1)

- (d) An oxide of lead that does **not** have the formula PbO contains 6.21 g of lead and 0.72 g of oxygen.

Calculate the empirical formula of this lead oxide.

Relative atomic masses (A_r): O = 16; Pb = 207

You must show your working to gain full marks.

.....
.....
.....
.....
.....
.....
.....

Empirical formula =

(4)
(Total 10 marks)

14

This question is about sodium chloride and iodine.

- (a) Describe the structure and bonding in sodium chloride.

.....
.....
.....
.....
.....
.....
.....
.....
.....
.....

(4)

- (b) When sodium chloride solution is electrolysed, one product is chlorine.

Name the **two** other products from the electrolysis of sodium chloride solution.

.....
.....

(2)

- (c) Many people do not have enough iodine in their diet.

Sodium chloride is added to many types of food. Some scientists recommend that sodium chloride should have a compound of iodine added.

Give **one** ethical reason why a compound of iodine should **not** be added to sodium chloride used in food.

.....
.....

(1)

- (d) The bonding in iodine is similar to the bonding in chlorine.

- (i) Complete the diagram below to show the bonding in iodine.

Show the outer electrons only.

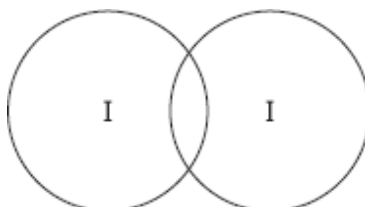

(2)

- (ii) Explain why iodine has a low melting point.

.....
.....
.....
.....
.....
.....

(3)

- (iii) Explain, in terms of particles, why liquid iodine does not conduct electricity.

.....
.....
.....
.....

(2)

(Total 14 marks)

15

Iron is extracted from iron oxide in the blast furnace.

(a) The equation for one of the reactions in the blast furnace is:



(i) Complete the word equation for this reaction.

**(2)**

(ii) Oxygen is removed from iron oxide in the blast furnace.

Draw a ring around the correct answer to complete the sentence.

The iron oxide is

neutralised.
oxidised.
reduced.

(1)

(b) The diagrams represent pure iron and iron from the blast furnace.

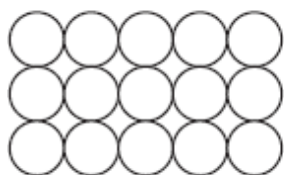

Pure iron

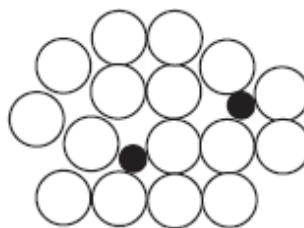

Iron from the blast furnace

(i) Draw **one** line from each statement to the correct explanation.

Statement	Explanation
Pure iron is an element because	it is made of one sort of atom only.
Iron from the blast furnace is a mixture because	it contains two elements not chemically combined.
	every atom has the same number of neutrons.
	it contains two elements chemically combined.

(2)

(ii) Explain why iron from the blast furnace is harder than pure iron.

Use the diagrams on page 4 to help you.

.....

.....

.....

.....

(2)
(Total 7 marks)

16

Diagram 1 shows the apparatus used to electrolyse magnesium sulfate solution.

Diagram 1

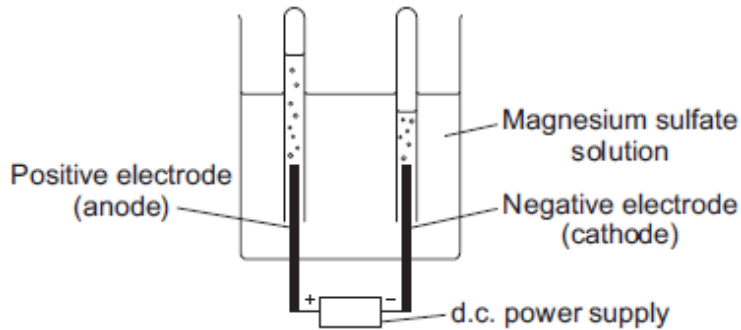

Gases were given off at both electrodes.

(a) The gas collected at the anode was oxygen.

Draw **one** line from the test for oxygen to the correct result.

Test	Result
	The splint relights
Place a glowing splint in the tube of the gas	The splint goes out
	There is a squeaky pop

(1)

(b) (i) The gas collected at the cathode was hydrogen.

Describe how to test the gas to show that it is hydrogen.

Test

Result

(2)

(ii) Why is hydrogen, and **not** magnesium, produced at the cathode?

.....
.....

(1)

(c) A student wanted to use electrolysis to silver plate a metal spoon.

(i) Give **one** reason why metal spoons are sometimes silver plated.

.....
.....

(1)

(ii) **Diagram 2** shows the apparatus the student used. The student did **not** set the apparatus up correctly.

Diagram 2

d.c. power supply

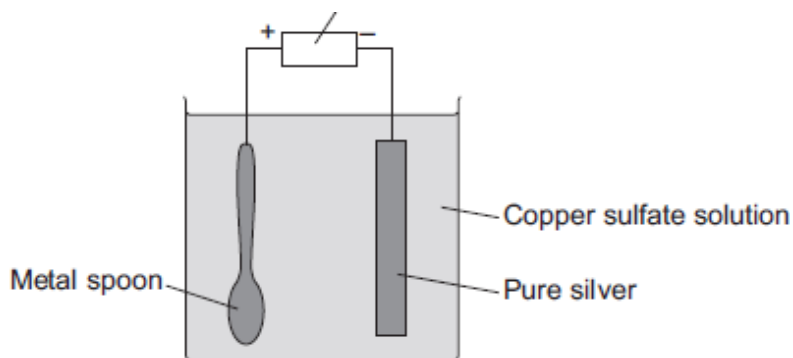

The student found that the metal spoon eroded and a thin layer of copper formed on the pure silver electrode.

Suggest **two** changes that the student must make to his apparatus to be able to silver plate the metal spoon. Give a reason for each change.

.....
.....
.....
.....
.....
.....
.....

(4)

(iii) Why is it difficult to electroplate plastic spoons?

.....
.....

(1)
(Total 10 marks)

17 A student was investigating a magnesium salt, **X**.

The student found that **X**:

- has a high melting point
- does not conduct electricity
- dissolves in water and the solution conducts electricity.

(a) (i) What is the type of bonding in magnesium salt **X**?

.....

(1)

(ii) Explain why solid **X** does **not** conduct electricity but a solution of **X** does conduct electricity.

.....
.....
.....
.....

(2)

(b) The student dissolved **X** in water.

The student added dilute nitric acid and silver nitrate solution to the solution of **X**.

A white precipitate was formed.

Salt **X** contains chloride ions.

Explain why a white precipitate was formed.

.....
.....
.....
.....

(2)

(c) The student dissolved **X** in water.

The student added a few drops of sodium hydroxide solution to the solution of **X**.

A white precipitate was formed.

(i) Salt **X** contains magnesium ions.

Name **two** other metal ions that would give a white precipitate when a few drops of sodium hydroxide solution are added.

1

2

(2)

(ii) Describe the **two** further tests the student would have to do to show that salt **X** contains magnesium ions, and **not** the two metal ions you identified in part (c) (i).

Give the expected results of each test.

.....
.....
.....
.....
.....
.....
.....
.....
.....

(4)

(Total 11 marks)

18

Glass is made from silicon dioxide.



© Velirina/iStock/Thinkstock

(a) Silicon dioxide has a very high melting point.

Other substances are added to silicon dioxide to make glass. Glass melts at a lower temperature than silicon dioxide.

Suggest why.

.....

.....

(1)

(b) Sodium oxide is one of the substances added to silicon dioxide to make glass.

(i) Sodium oxide contains Na^+ ions and O^{2-} ions.

Give the formula of sodium oxide.

.....

(1)

(ii) Sodium oxide is made by heating sodium metal in oxygen gas.

Complete the diagram to show the outer electrons in an oxygen molecule (O_2).

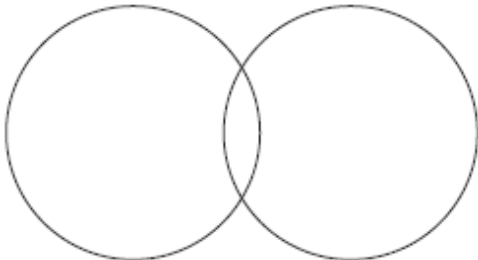

(2)

(c) Glass can be coloured using tiny particles of gold. Gold is a metal.

Describe the structure of a metal.

.....

.....

.....

.....

.....

.....

(3)
(Total 7 marks)

19

Kelp is a seaweed.

Kelp can be used in foods and as a renewable energy source.



© Ethan Daniels/Shutterstock

(a) Scientific experiments, on their own, **cannot** fully answer one of the following questions. Which one?

Tick (✓) **one** box.

Questions	Tick (✓)
How much carbon dioxide is produced when 100 g of kelp is burned?	
Does kelp give out more heat energy than coal?	
Will kelp last longer than coal as an energy source?	
Which fuel, kelp or coal, produces the most ash when burned?	

(1)

(b) Scientists cannot answer the question 'should people use kelp instead of coal as an energy source?'

Give **two** reasons why.

.....
.....
.....
.....

(2)

(c) Sodium iodide can be produced from kelp.

(i) How many electrons are in the outer shell of an iodine atom?

(1)

(ii) Sodium iodide contains sodium ions (Na^+) and iodide ions (I^-).

Describe, as fully as you can, what happens when sodium atoms react with iodine atoms to produce sodium iodide.

You may use a diagram in your answer

.....
.....
.....
.....
.....
.....

(3)

- (iii) The diagram shows the structure of sodium iodide.

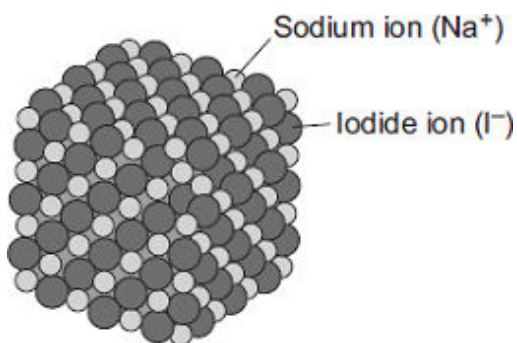

Solid sodium iodide does not conduct electricity.

Why does sodium iodide solution conduct electricity?

.....

(1)

- (iv) When sodium iodide solution is electrolysed, iodine is formed at the positive electrode.

Complete and balance the half equation for the formation of iodine.

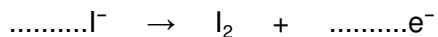

(1)

- (v) What is formed at the negative electrode when sodium iodide solution is electrolysed?

Explain why.

.....

(2)

(Total 11 marks)

20

Silicon dioxide is used as a lining for furnaces.

Furnaces can be used to melt iron for recycling.



© Oleksiy Mark/iStock

The diagram shows a small part of the structure of silicon dioxide.

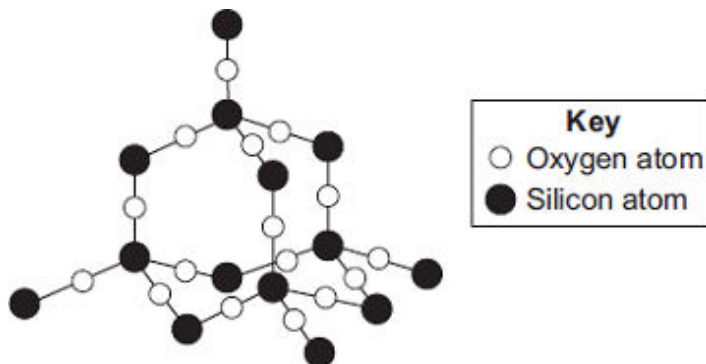

Explain why silicon dioxide is a suitable material for lining furnaces.

.....

.....

.....

.....

.....

.....

.....

.....

(Total 4 marks)

21

The hip joint sometimes has to be replaced.
Early replacement hip joints were made from stainless steel.

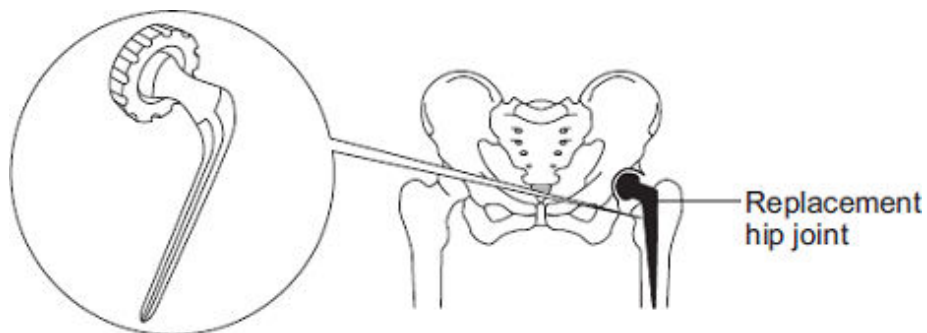

Stainless steel is an alloy of iron, chromium and nickel.
The diagram below represents the particles in stainless steel.

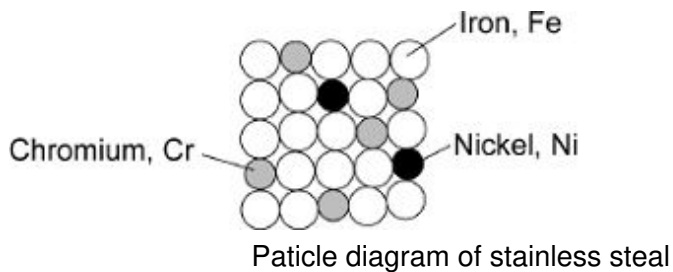

(a) Use the diagram to complete the percentages of metals in this stainless steel.

The first one has been done for you.

Element	Percentage (%)
Iron, Fe	72
Chromium, Cr	
Nickel, Ni	

(2)

(b) Pure iron is a soft, metallic *element*.

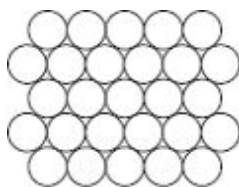

(i) Why is iron described as an *element*?

.....

.....

(1)

(ii) Pure iron would **not** be suitable for a replacement hip joint.

Suggest why.

.....
.....

(1)

(iii) The three metals in stainless steel have different sized atoms.
Stainless steel is harder than pure iron.

Explain why.

.....
.....
.....
.....

(2)

(Total 6 marks)

22

Oil rigs are used to drill for crude oil.



© Digital Vision/Photodisc

(a) Drill heads are made from steel. Steel is an alloy.

Explain why alloys are harder than pure metals.

.....
.....
.....
.....
.....
.....

(3)

(b) Drill heads also contain diamonds.

Describe, as fully as you can, the structure and bonding in diamond.

.....

.....

.....

.....

.....

.....

.....

.....

(4)

(c) Polymers are produced from crude oil.

Describe the structure and bonding in a thermosoftening polymer and explain why thermosoftening polymers melt when heated.

.....

.....

.....

.....

.....

.....

.....

.....

(4)
(Total 11 marks)

23

Spacecraft have been to the planets Venus and Mars. The spacecraft have sent back information about the atmosphere of each planet.

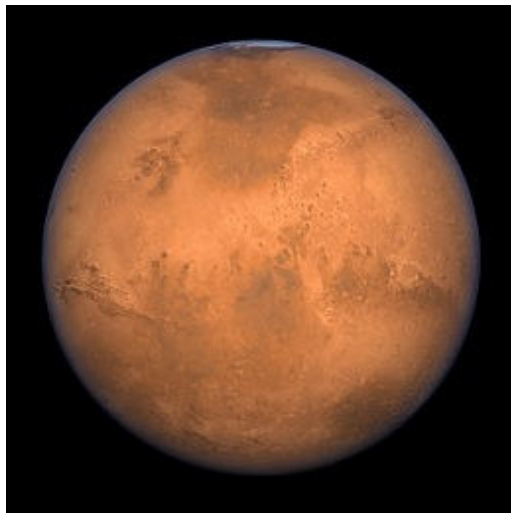

© Tristan3D/Shutterstock

(a) The main gas in the atmosphere of Mars is carbon dioxide.

Explain why, in terms of structure, carbon dioxide is a gas, even at low temperatures.

.....
.....
.....
.....
.....
.....
.....
.....

(3)

(b) The atmosphere on Venus contains droplets of sulfuric acid solution.

(i) Suggest a pH value for sulfuric acid solution.

pH =

(1)

(ii) Name the ion which makes sulfuric acid solution acidic.

.....

(1)

(c) The atmosphere of Venus contains the isotopes ${}^2_1\text{H}$ and ${}^1_1\text{H}$

Describe the similarities and the differences in the isotopes ${}^2_1\text{H}$ and ${}^1_1\text{H}$

You should refer to the sub-atomic particles in each isotope.

.....

.....

.....

.....

.....

.....

.....

.....

(3)
(Total 8 marks)

24

The diagrams represent the structures of five substances, **A**, **B**, **C**, **D** and **E**.

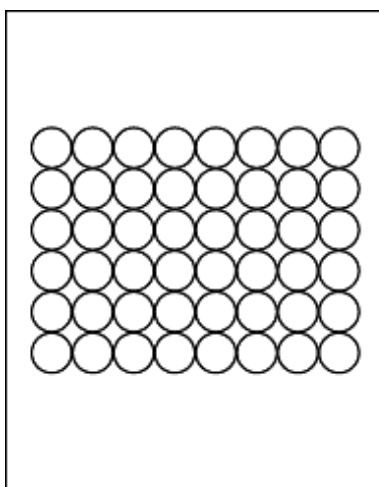
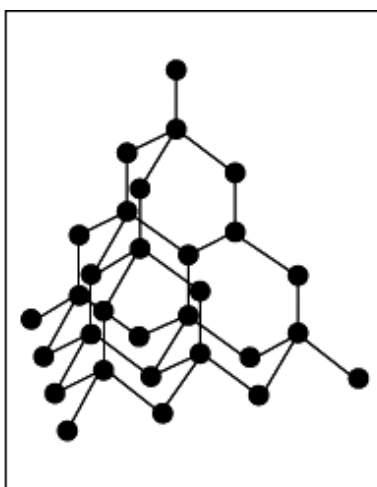
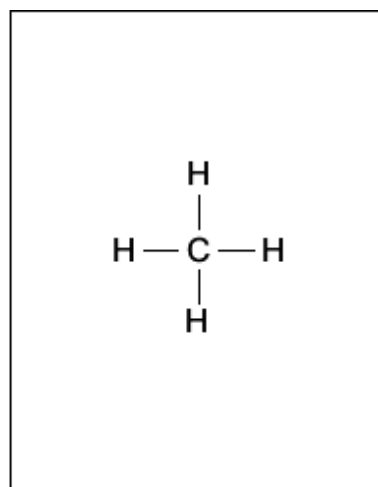
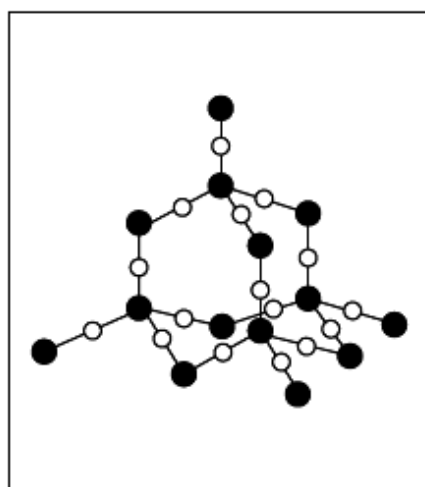
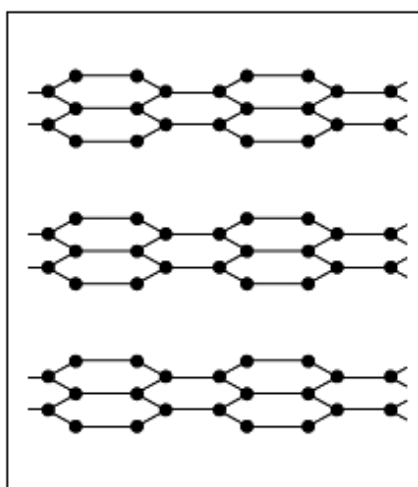
**A****B****C****D****E**

(a) Give **one** substance, **A**, **B**, **C**, **D** or **E**, that:

(i) has a very low boiling point

(1)

(ii) is a compound

(1)

(iii) is a metal.

(1)

(b) Draw a ring around the type of bonding holding the atoms together in substance **C**.

covalent

ionic

metallic

(1)

(c) Explain why substance **E** is soft and slippery.

.....

.....

.....

.....

(2)

(Total 6 marks)

25

The diagram shows how a heat sink is placed on top of a processor in a computer. The heat sink is a large piece of metal which conducts heat away from the processor. If the processor gets too hot it may be damaged.

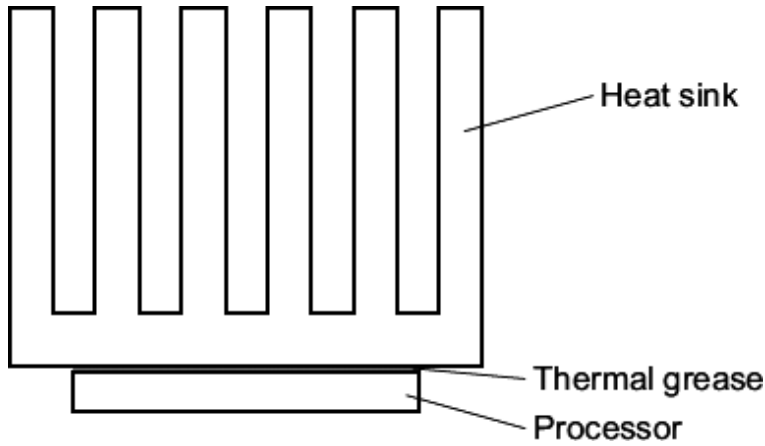

(a) (i) Describe the structure of a metal.

.....

.....

.....

.....

.....

.....

.....

.....

(3)

(ii) Why are metals very good conductors of heat?

.....

.....

(1)

- (b) When viewed under a microscope, it can be seen that the surfaces of the processor and the heat sink that are in contact are not flat. There are lots of tiny gaps between the two surfaces. The gaps contain air, which does not conduct heat very well. Thermal grease is used to fill the gaps between the processor and the heat sink to improve the transfer of heat from the processor to the heat sink.

One type of thermal grease contains nanosized particles of silver. The manufacturer claims that the nanosized particles help to transfer heat better than normal sized particles.

- (i) How are nanosized particles different from normal sized particles?

.....

(1)

- (ii) Suggest **one** reason why nanosized particles of silver might help to transfer heat better than normal sized particles.

.....

(1)

(Total 6 marks)

26

The picture shows two different cars.



- (a) Some properties of aluminium are given below.

Tick (✓) **two** reasons why aluminium is better than steel for car bodies.

Reason	Tick (✓)
Aluminium is not a transition metal.	
Aluminium has a low density.	
Aluminium is expensive to extract.	
aluminium is resistant to corrosion.	

(2)

(b) Each car body is made from an *alloy*.

(i) What is an *alloy*?

.....

(1)

(ii) An alloy is used to make a car body. A pure metal is **not** used to make a car body.

Suggest why.

.....

(1)

(c) The car with a steel body uses petrol for fuel.

Draw a ring around the correct answer to complete each sentence.

(i) Petrol is made from

air.
crude oil.
metal ores.

(1)

(ii) Petrol is a mixture of

carbonates	including C ₈ H ₁₈
hydrocarbons	
polymers	

(1)

(iii) In the car engine petrol reacts with

argon
nitrogen
oxygen

to produce carbon dioxide and water.

(1)

(d) Look at the substances coming out of each car's exhaust.

(i) Suggest the name of the fuel used in the car with the aluminium alloy body.

Name of fuel

(1)

- (ii) Why is the fuel burned in the car with the aluminium alloy body better for the environment than petrol?

.....

(1)
 (Total 9 marks)

27

Read the information

Graphene

Scientists have made a new substance called graphene.
 The bonding and structure of graphene are similar to graphite.

Graphene is made of a single layer of the same atoms as graphite.



Graphene

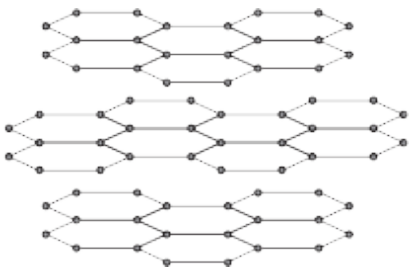

Graphite

Use the information above and your knowledge of graphite to answer the questions.

- (a) This part of the question is about graphene.

Choose the correct answer to complete each sentence.

(i)

ionic covalent metallic

The bonds between the atoms in graphene are

(1)

(ii)

chromium carbon chlorine

Graphene is made of atoms.

(1)

(iii)

2 3 4

In graphene each atom bonds to other atoms.

(1)

(b) This part of the question is about graphite.

Graphite is used in pencils.

Explain why. Use the diagrams to help you.

.....

.....

.....

.....

(2)
(Total 5 marks)

28

This question is about gold (Au).

(a) An atom of gold is represented as:

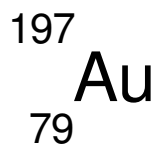

How many neutrons are in this atom of gold?

(1)

(b) Gold ions are used as a catalyst.

How does a gold atom (Au) become a gold ion (Au³⁺)?

.....

.....

.....

.....

(2)

(c) A gold catalyst can be used when carbon monoxide reacts with oxygen to make carbon dioxide.

(i) Complete and balance the equation for this reaction.



(2)

(ii) Carbon dioxide has a very low boiling point.

Explain why.

.....
.....
.....
.....
.....
.....

(3)

(d) Gold is used as a catalyst in industrial processes. Gold is rare and increasingly expensive.

Suggest **three** reasons why gold is still used in industrial processes.

.....
.....
.....
.....
.....
.....

(3)

(Total 11 marks)

29

Stage smoke is used for special effects at pop concerts.



By Sam Cockman [CC BY 2.0], via Flickr

Ammonium chloride can be used to make stage smoke.

Ammonium chloride is a white solid.

When heated, ammonium chloride produces white smoke which can be blown onto the stage.

The equation shows what happens when ammonium chloride is heated and cooled.

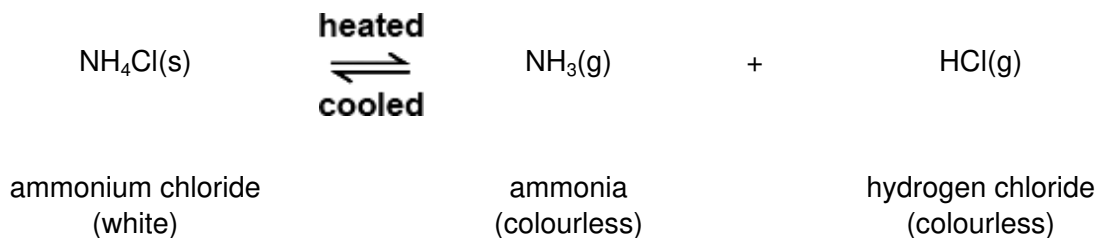

(a) The sentences explain how the smoke is made.

Draw a ring around the correct answer in each box to complete each sentence.

Use the information and the equation to help you.

When heated, ammonium chloride makes two colourless

solids.

liquids.

gases.

These are blown into the air where they cool and make a

colourless

black

white

solid.

liquid.

gas.

ammonia.

which is

ammonium chloride.
hydrogen chloride.

(4)

(b) Complete the sentence.

The symbol \rightleftharpoons means that the reaction is

(1)

(Total 5 marks)

30

High quality connectors are used to connect a satellite box to a television. The connectors should conduct electricity very well and should not corrode.



By Alphathon (Own work) [CC-BY-SA-3.0 or GFDL], via Wikimedia Commons

The connectors on this scart lead are coated with gold.

(a) Gold is a typical metal.

(i) Describe the structure and bonding of gold.

.....

.....

.....

.....

.....

.....

.....

.....

(3)

(ii) Why is gold a good conductor of electricity?

.....
.....

(1)

(b) The surface of some metals, such as iron, corrode when exposed to the air.

Suggest why this reduces the electrical conductivity of the metal.

.....
.....
.....
.....

(2)

(Total 6 marks)

31

The diagram shows an electric plug.

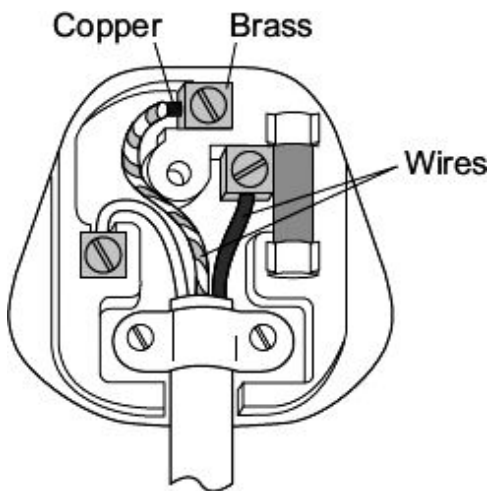

(a) (i) Draw a ring around the correct answer to complete the sentence.

Copper is used for the wires because it

conducts electricity.

conducts heat.

is shiny.

(1)

(ii) Brass is an *alloy* of copper and zinc.

What is an *alloy*?

.....
.....

(1)

(b) Open-cast mines are used to obtain copper ore.

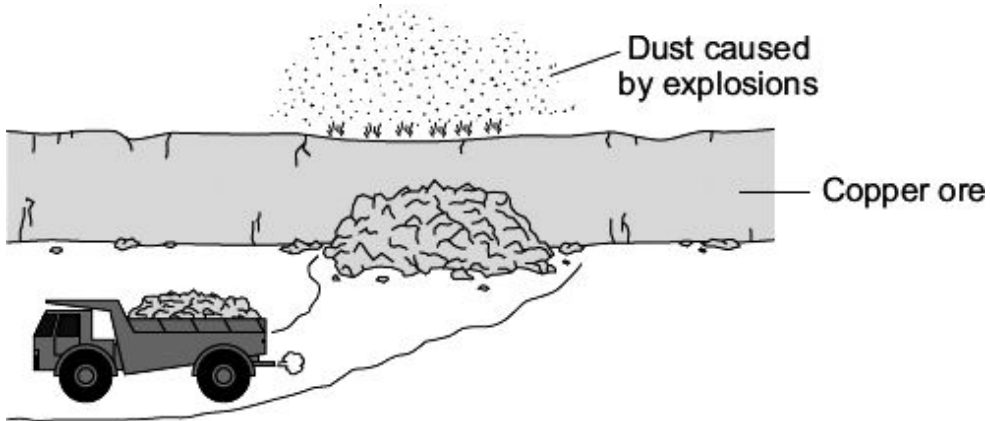

Suggest **two** reasons why people would **not** like to live near an open-cast mine.

1

.....

2

.....

(2)
(Total 4 marks)

32

The picture shows a wooden bowl.
The pieces of wood used for this bowl were dyed different colours.



By Bertramz (Own work) [CC-BY-SA-3.0], via Wikimedia Commons

The artist who made the bowl explained why he dissolved the coloured dyes in methanol.

I use different coloured dyes dissolved in methanol.
I use methanol because with dyes dissolved in water the wood needs to be soaked for a longer time.
The bowl dries more quickly if I use methanol instead of water.

(a) The artist uses methanol instead of water.

Give **two** reasons why.

1

.....

2

.....

(2)

- (b) The diagram shows how the atoms are bonded in methanol.

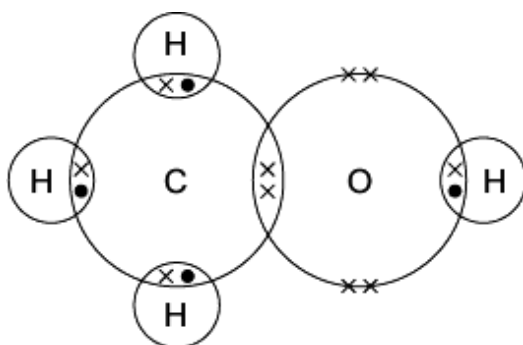

Draw a ring around:

- (i) the formula of methanol



(1)

- (ii) the type of bonding in methanol.

covalent

ionic

metallic

(1)

- (c) Methanol has a low boiling point.

Tick (✓) the reason why.

Reason why	Tick (✓)
It has a giant covalent structure.	
It is made of small molecules.	
It has a giant metallic structure.	

(1)
(Total 5 marks)

33

- (a) A magnesium atom contains 12 protons (●), 12 neutrons (○) and 12 electrons (x).

Which diagram, **A**, **B** or **C**, represents this magnesium atom?

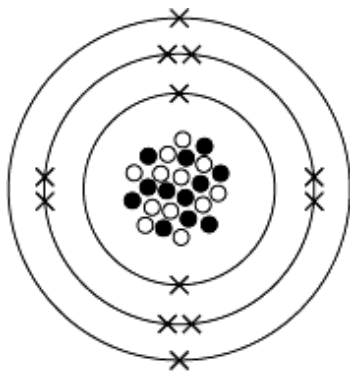

Diagram A

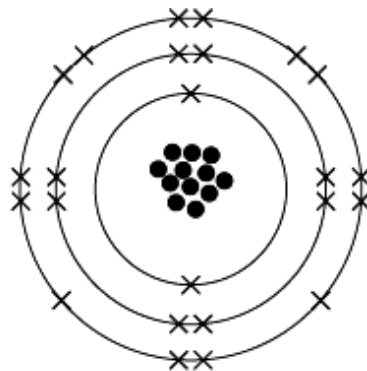

Diagram B

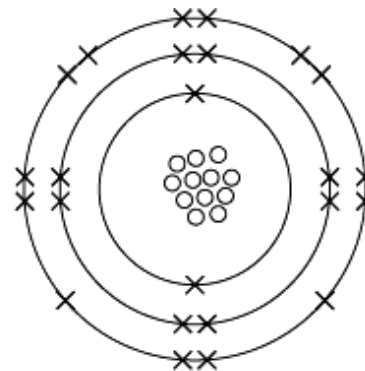
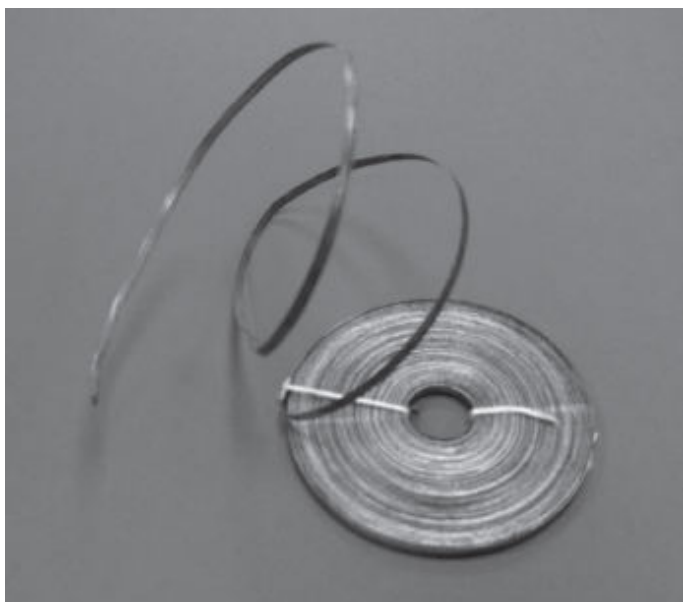

Diagram C

This magnesium atom is **Diagram**

(1)

- (b) Magnesium metal is shaped to make magnesium ribbon.



Tick (✓) **two** reasons which explain why metals can be shaped.

Reason why	Tick (✓)
The atoms are all joined by covalent bonds.	
The atoms can slide over each other.	
The atoms are large.	
The atoms are in layers.	

(2)

- (c) Magnesium sulfate is a salt of magnesium.

It can be prepared by the reaction of magnesium metal with an acid. The equation for the reaction of magnesium with this acid is:

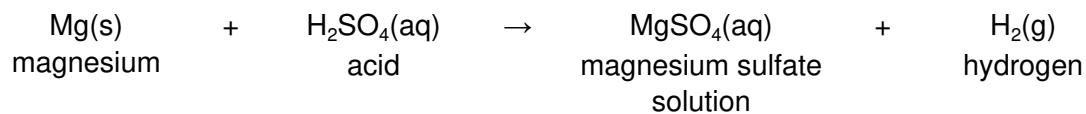

- (i) Draw a ring around the name of the acid used in this reaction.

hydrochloric

nitric

sulfuric

(1)

(ii) Use the equation to help you to answer this question.

Tick (✓) **two** things that happen when this reaction takes place.

	Tick (✓)
Bubbles are produced.	
The magnesium disappears.	
A solid is formed.	
Water is formed.	

(2)

(iii) Draw a ring around a method to get solid magnesium sulfate from magnesium sulfate solution.

crystallisation

electrolysis

oxidation

(1)

(Total 7 marks)

34

Welding blankets are placed under metals being welded. They protect the area under the welding from hot sparks or molten metal.



Welding blanket

Some welding blankets are made from silicon dioxide.

(a) The table lists some properties of materials.

Two of these are properties of materials used to make welding blankets.

Tick (✓) the **two** correct properties.

Property	Tick (✓)
High melting point	
Reacts with sparks	
Not flammable	
Low boiling point	

(2)

- (b) Silicon dioxide has a giant structure. The diagram shows a small part of this structure.

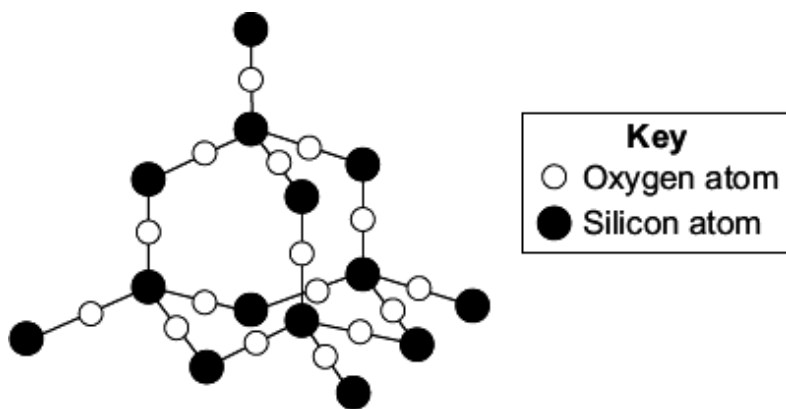

Draw a ring around the correct answer to complete each sentence.

- (i) Silicon dioxide has a high melting point because a few
some
all of the atoms are joined to other atoms.

(1)

- (ii) Each oxygen atom is joined to two
three
four silicon atoms.

(1)

- (iii) The bonds between the atoms are covalent.
ionic.
metallic.

(1)

- (iv) These bonds are easily broken.
very strong.
weak.

(1)

(Total 6 marks)

35

- (a) Magnesium metal is shaped to make magnesium ribbon.

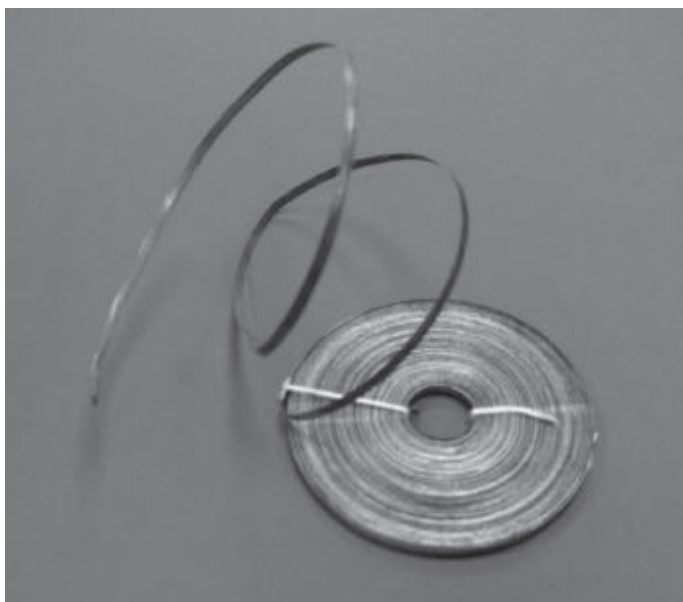

Explain why metals can be shaped.

.....

.....

.....

.....

.....

(2)

- (b) Magnesium sulfate is a salt of magnesium.

It can be prepared by the reaction of magnesium metal with an acid. The equation for the reaction of magnesium with this acid is:

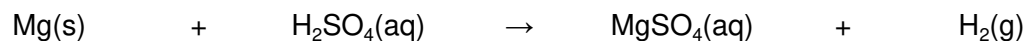

- (i) Name the acid used to make magnesium sulfate.

..... acid

(1)

- (ii) Use the equation to help you to describe what you would **observe** when magnesium reacts with the acid.

.....
.....
.....
.....
.....

(2)

- (iii) The magnesium sulfate is in solution.

How could you obtain solid magnesium sulfate from this solution?

.....
.....

(1)

(Total 6 marks)

36

Welding blankets are placed under metals being welded. They protect the area under the welding.



Welding blanket

Some welding blankets are made from silicon dioxide which does not melt when hit by sparks or molten metal.

The diagram shows a small part of the structure of silicon dioxide.

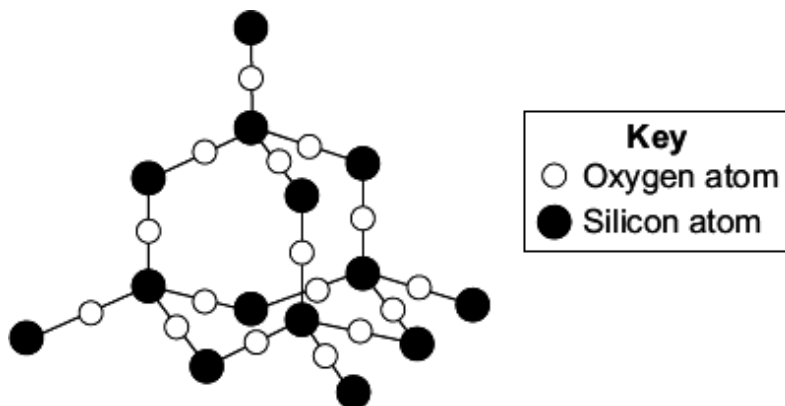

Describe the structure and bonding in silicon dioxide **and** explain why it is a suitable material for making welding blankets.

.....

.....

.....

.....

.....

.....

.....

(3)
(Total 3 marks)

37

Read the information in the box.

Flash powder is used to produce special effects at pop concerts.



Flash powder contains aluminium. The powder burns with a bright white flame and gives out lots of heat and light. It also produces white smoke.

The flash powder is placed on stage in a special container. At the bottom of the container there is a thin piece of wire. When the flash is needed, electricity is passed through the wire. The wire gets hot and starts the aluminium burning.

By russellsmith [CC BY 2.0], via Flickr

- (a) When aluminium burns the reaction is
- exothermic*
- .

What is the meaning of *exothermic*?

.....

(1)

- (b) The hot wire provides energy to start the aluminium burning.

What is the name given to the heat energy needed to start a chemical reaction?

..... energy

(1)

- (c) The white smoke produced is aluminium oxide.

Aluminium oxide contains aluminium ions (Al^{3+}) and oxide ions (O^{2-}).

- (i) Complete the diagram to show the electronic structure of an oxide ion.

The atomic number of oxygen = 8

Use crosses (x) to represent the electrons.

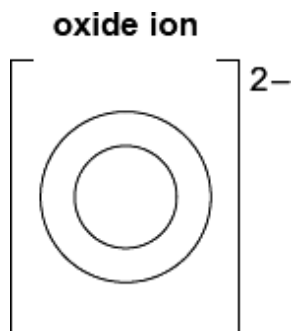

(1)

- (ii) The bonding in aluminium oxide is ionic.

What causes the aluminium ions and oxide ions to be held together strongly?

.....

.....

(1)
(Total 4 marks)

38

Lead compounds have been used for thousands of years as colours in paint.



Johannes Vermeer [Public domain], via Wikimedia Commons

- (a) A sample of a red oxide used in paint was found to contain 6.21 g of lead and 0.64 g of oxygen.

Calculate the empirical (simplest) formula of this compound.

You **must** show all your working to gain full marks.

Relative atomic masses: O = 16; Pb = 207.

.....

.....

.....

.....

.....

.....

.....

.....

.....

.....

.....

(4)

(b) A problem with lead compounds is that they slowly react with hydrogen sulfide in the air. This produces lead sulfide which is black.

(i) Hydrogen sulfide has the formula H_2S . The bonding in a molecule of hydrogen sulfide can be represented as:

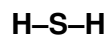

Complete the diagram below to show the arrangement of the outer electrons of the hydrogen and sulfur atoms in hydrogen sulfide.

Use dots (•) and crosses (x) to represent the electrons.

You need only show the outer shell electrons.

(Atomic numbers: H = 1; S = 16.)

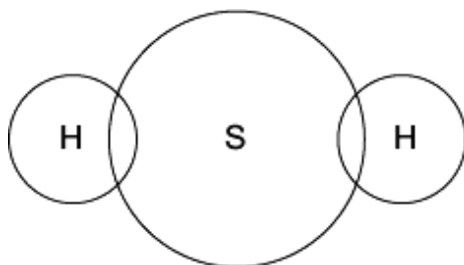

(1)

(ii) Hydrogen sulfide has a low boiling point.

Explain why.

.....

.....

.....

.....

(2)

(iii) Lead white is also used in paint. The white colour slowly darkens when lead sulfide is produced.

The painting can be restored with hydrogen peroxide. This converts the black lead sulfide into white lead sulfate.

Balance the equation for the reaction between lead sulfide and hydrogen peroxide (H_2O_2).

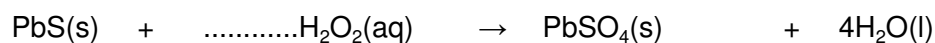

(1)

(Total 8 marks)

39

Metal is bent and shaped to make a car body.



The diagram below represents how atoms are arranged in a metal.



Which **two** statements in the table best explain why the metal can be bent and shaped?

Tick (✓) the **two** statements.

Statement	Tick (✓)
The atoms are in layers.	
The metal is shiny.	
The atoms can slide over each other.	
All the atoms are linked by strong covalent bonds.	

(2)
(Total 2 marks)

40

Firework rockets contain fuel and potassium nitrate.

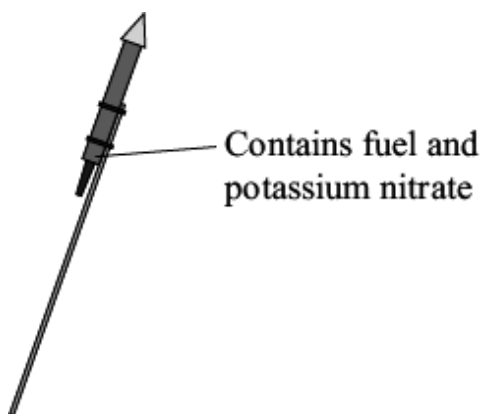

The potassium nitrate provides oxygen for the fuel to react.

- (a) The table shows how a student worked out the relative formula mass (M_r) of potassium nitrate.

Some of the numbers are missing.

Relative atomic masses (A_r): N = 14; O = 16; K = 39.

Name of atom (symbol)	Number of atoms	A_r	Mass
potassium (K)	1	39	39
nitrogen (N)	1	14	14
oxygen (O)		16	
The M_r of potassium nitrate =			101

- (i) The mass of oxygen is not shown in the table.

Draw a ring around the correct mass of oxygen.

16

32

48

(1)

- (ii) Draw a ring around the number of oxygen atoms in the formula of potassium nitrate.

1

2

3

(1)

- (b) When the fuel reacts with the oxygen an *exothermic* reaction takes place.

What does *exothermic* mean?

.....

.....

.....

.....

(2)

- (c) The fuel contains carbon. Carbon reacts with oxygen to make carbon dioxide.

Which **two** statements in the table explain why carbon dioxide is a gas at room temperature?

Tick (✓) the **two** statements.

Statement	Tick (✓)
It has a giant structure	
It has a low boiling point.	
It is made of small molecules.	
It is made of ions.	

(2)
(Total 6 marks)

41

- (a) The table gives information about two isotopes of hydrogen, hydrogen-1 and hydrogen-2.

	Hydrogen-1	Hydrogen-2
Atomic number	1	1
Mass number	1	2

An atom of hydrogen-1 is represented as: ${}^1_1\text{H}$

Show how an atom of hydrogen-2 is represented.

(1)

- (b) (i) Calculate the relative formula mass (M_r) of water, H_2O

Relative atomic masses: H = 1; O = 16.

.....

Relative formula mass (M_r) =

(1)

- (ii) Simple molecules like water have low boiling points.

Explain why, in terms of molecules.

.....

(2)

- (c) Molecules of heavy water contain two atoms of hydrogen-2 instead of two atoms of hydrogen-1.

Explain why a molecule of heavy water has more mass than a normal water molecule. You should refer to the particles in the nucleus of the two different hydrogen atoms in your answer.

.....

.....

.....

.....

.....

(2)
(Total 6 marks)

42

The picture shows a copper kettle being heated on a camping stove.

Copper is a good material for making a kettle because:

- it has a high melting point
- it is a very good conductor of heat.

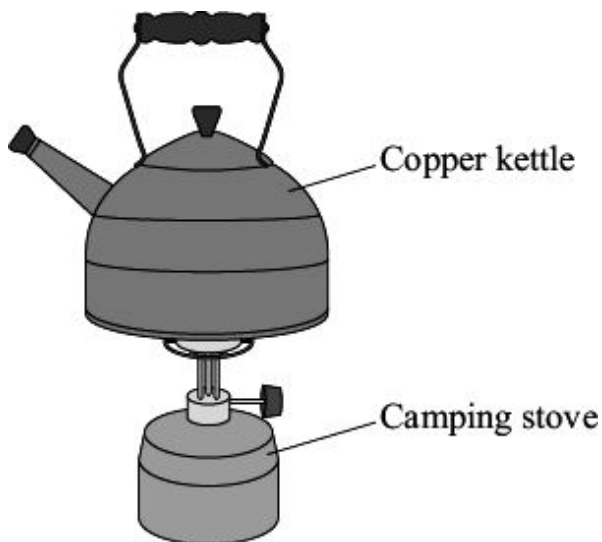

- (a) Explain why copper, like many other metals, has a high melting point. You should describe the structure and bonding of a metal in your answer.

.....

.....

.....

.....

.....

.....

.....

.....

.....

(4)

- (b) An aeroplane contains many miles of electrical wiring made from copper. This adds to the mass of the aeroplane.

It has been suggested that the electrical wiring made from copper could be replaced by lighter carbon nanotubes.

The diagram shows the structure of a carbon nanotube.

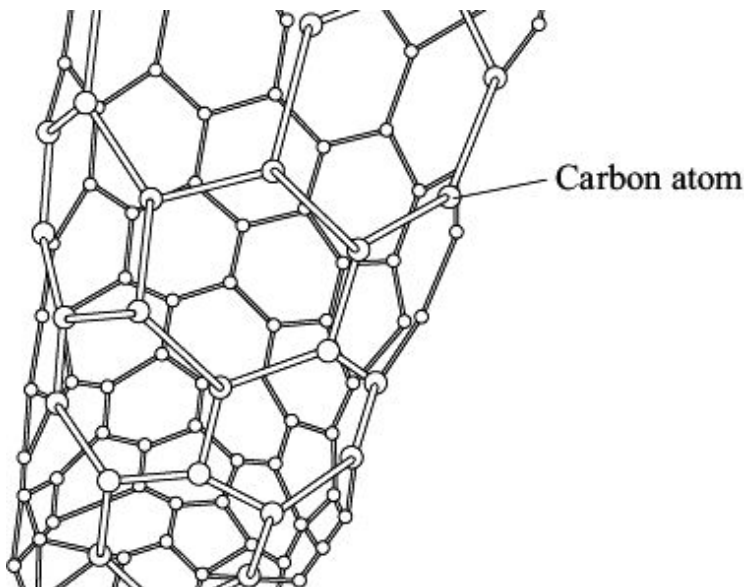

- (i) What does the term 'nano' tell you about the carbon nanotubes?

.....
.....

(1)

- (ii) Like graphite, each carbon atom is joined to three other carbon atoms.

Explain why the carbon nanotube can conduct electricity.

.....
.....
.....
.....

(2)

(Total 7 marks)

43

This question is about some compounds of iodine.

- (a) Lead iodide can be made by mixing a solution containing lead ions with a solution containing iodide ions.

Lead iodide is formed as a precipitate.

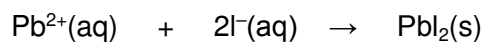

- (i) The table below gives information about the solubility of some compounds.

Soluble compounds	Insoluble compounds
all sodium and potassium salts	
all nitrates	
most chlorides, bromides and iodides	silver and lead chlorides, bromides and iodides

Use the table to help you name:

a soluble compound which contains lead ions

a soluble compound which contains iodide ions

(2)

- (ii) Suggest a method of separating the lead iodide from the solution.

.....

(1)

(b) Magnesium iodide can be made by reacting magnesium with iodine.

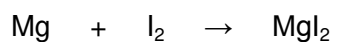

Magnesium iodide is an ionic compound. It contains magnesium ions (Mg^{2+}) and iodide ions (I^-).

Describe, in terms of electrons, what happens when magnesium reacts with iodine.

.....

.....

.....

.....

.....

.....

.....

.....

.....

.....

.....

.....

(4)

- (c) The diagram shows the structure of potassium iodide.

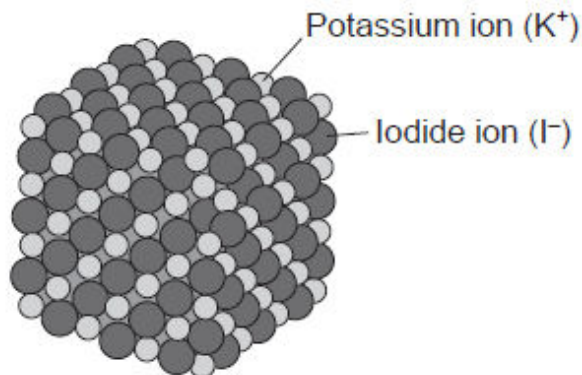

Explain why a high temperature is needed to melt potassium iodide.

.....

.....

.....

.....

(2)
(Total 9 marks)

44

Iron is the main structural metal used in the world.

- (a) The diagram represents the particles in iron, Fe.

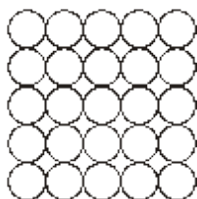

Draw a ring around the correct word in the box to complete the sentence.

Iron is described as an element because all the

atoms

compounds

metals

are the same.

(1)

(b) Stainless steel is mostly iron.

The diagram represents the particles in stainless steel.

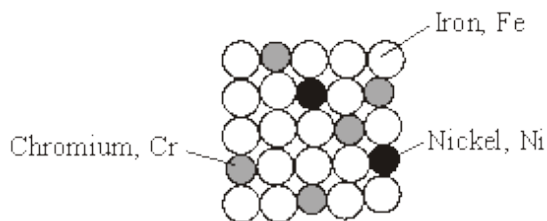

Use the correct words from the box to complete the sentences about alloys.

metal mixture molecule polymer smart structure

Stainless steel is an alloy because it is a of iron, chromium and nickel.

An alloy is made up of more than one type of

Stainless steel alloys are harder than iron because the different sized atoms added change the

An alloy that can return to its original shape after being deformed is called a alloy.

(4)

(c) In the UK, we use about 1.8 billion steel cans every year but only 25% are recycled. Used steel cans are worth about £100 per tonne.

Recycling saves raw materials and reduces waste that would end up in landfill. Producing steel by recycling used cans saves 75% of the energy that would be needed to produce steel from iron ore. This also reduces carbon dioxide emissions.

(i) Give **two** reasons, from the information above, to explain why recycling used steel cans is a good idea.

1

.....

2

.....

(2)

- (ii) Suggest how the local council could increase the percentage of used steel cans that are recycled.

.....

.....

(1)
(Total 8 marks)

45

The hip joint between the femur and pelvis sometimes has to be replaced. Early hip replacement joints were made from stainless steel.

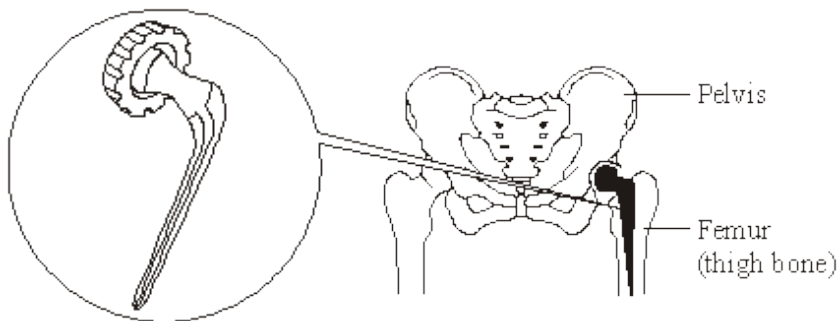

Stainless steel is an alloy of iron, chromium and nickel.

The diagram below represents the particles in stainless steel.

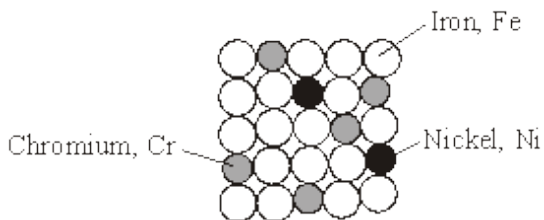

Particle diagram of stainless steel

- (a) Use the particle diagram to complete the percentages of metals in this stainless steel.

The first one has been done for you.

Element	Percentage (%)
Iron, Fe	72
Chromium, Cr	
Nickel, Ni	

(2)

(b) Pure iron is a relatively soft, metallic element.

(i) Why is iron described as an *element*?

.....
.....

(1)

(ii) Suggest why pure iron would **not** be suitable for a hip replacement joint.

.....
.....

(1)

(iii) Use the particle diagram to help you to explain why stainless steel is harder than pure iron.

.....
.....
.....
.....

(2)

(Total 6 marks)

46

This barbecue burns propane gas.

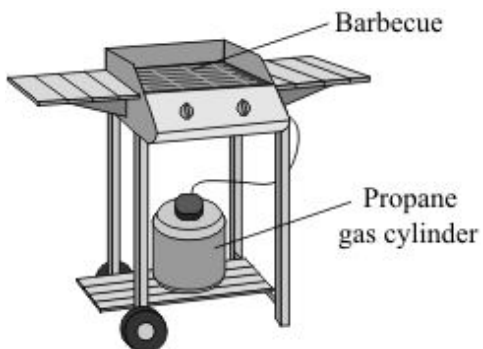

The diagram represents a propane molecule.

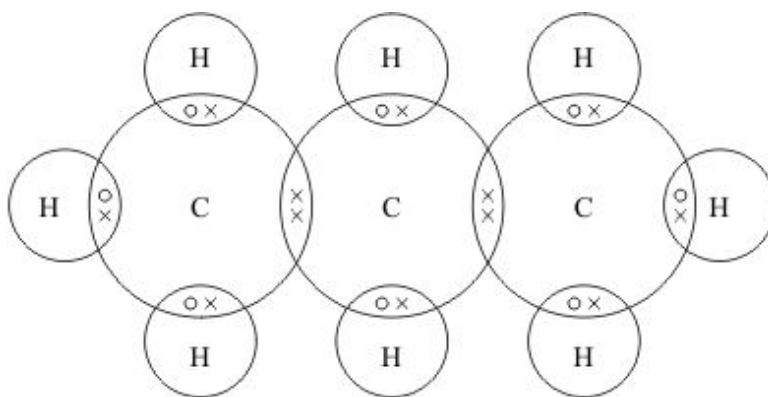

(a) What is the formula of propane?

(1)

(b) (i) Draw a ring around the name of the particle represented by the symbols \circ and \times in the diagram.

electron

neutron

proton

(1)

(ii) Draw a ring around the type of bonding that holds the atoms together in a propane molecule.

covalent

ionic

metallic

(1)

(c) Under high pressure in the cylinder propane is a liquid.
Liquid propane evaporates easily to form a gas when the tap on the cylinder is opened.

Draw a ring around the correct answer in each box to explain why propane evaporates easily.

Propane has a	high low	boiling point because it consists of	large small	molecules.
---------------	-------------	--------------------------------------	----------------	------------

(1)

(Total 4 marks)

47

The following steps show how to use a type of glue.

Step 1 Measure out equal amounts of the liquids from tubes **A** and **B**.



Step 2 Mix the liquids to make the glue.

Put a thin layer of the glue onto each of the surfaces to be joined.

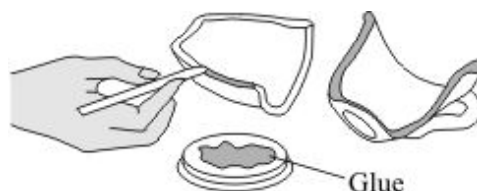

Step 3 Assemble the pieces to be joined and then hold them together with tape.

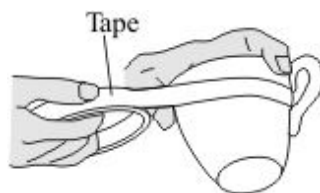

Step 4 Leave the glue to set.

(a) When liquids **A** and **B** are mixed a chemical reaction takes place.

(i) This reaction is exothermic.

Complete the sentence below using a word or phrase from the box.

decrease	increase	stay the same
----------	----------	---------------

During the reaction the temperature of the mixture will

(1)

(ii) When the glue sets it forms a giant covalent structure.

Draw a ring around **one** property that you would expect the set glue to have.

good conductor of electricity low melting point high melting point

(1)

- (b) The time taken for the glue to set at different temperatures is given in the table below.

Temperature in °C	Time taken for the glue to set
20	3 days
60	6 hours
90	1 hour

- (i) Complete the sentences below using words or phrases from the box.

decrease	increase	stay the same
-----------------	-----------------	----------------------

When the temperature is increased the time taken for the glue to set

.....

When the temperature is increased the rate of the setting reaction

.....

(2)

- (ii) Put a tick (✓) next to the **two** reasons why an increase in temperature affects the rate of reaction.

Reason	(✓)
It gives the particles more energy.	
It increases the concentration of the particles.	
It increases the surface area of the particles.	
It makes the particles move faster.	

(2)

(Total 6 marks)

48

This barbecue burns propane gas.

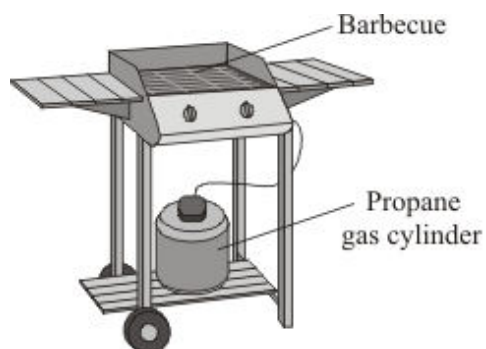

The structure of propane is shown below.

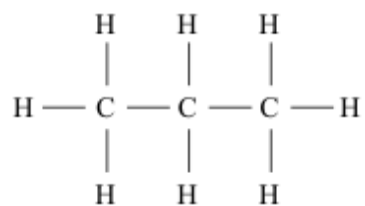

- (a) Complete the diagram to show how the outer energy level (shell) electrons of hydrogen and carbon are arranged in a molecule of propane.

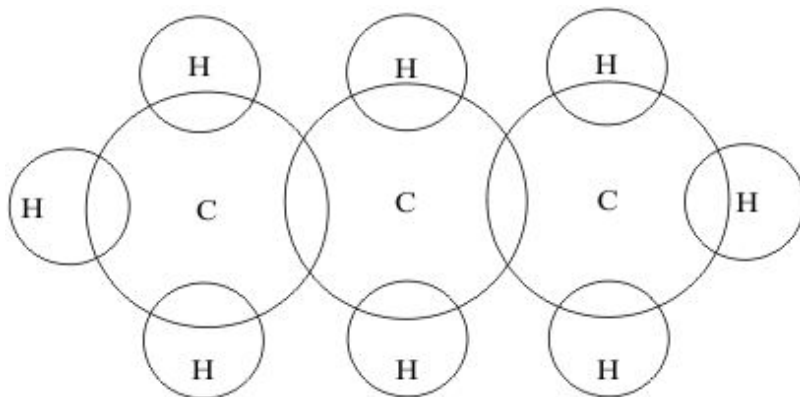

(1)

(b) The graph shows how the vapour pressure of propane changes with temperature.

The vapour pressure of a liquid is the pressure of the vapour above the liquid.

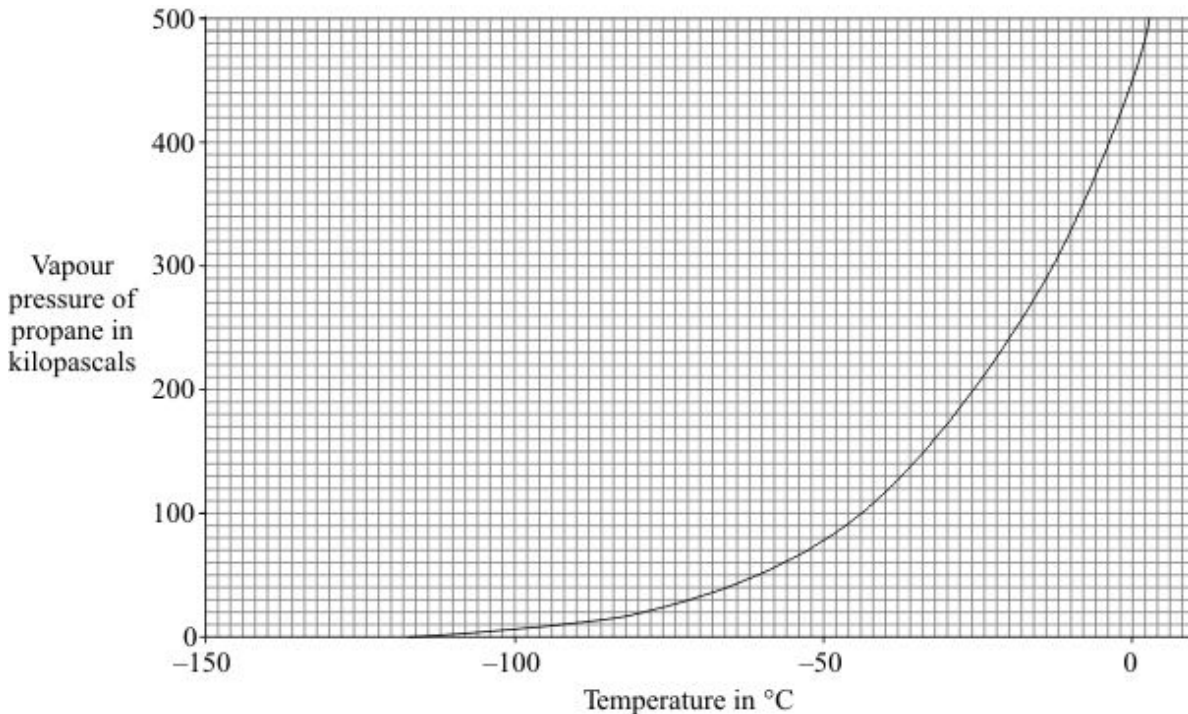

(i) Describe, as fully as you can, how the vapour pressure of propane changes with temperature.

.....
.....
.....
.....
.....

(2)

(ii) The boiling point of a liquid is the temperature at which its vapour pressure is equal to the air pressure above the liquid.

Use the graph to find the boiling point of propane when the air pressure is 100 kilopascals.

Boiling point °C

(1)

(c) Explain, in terms of molecules, why propane has a low boiling point.

.....

.....

.....

.....

.....

(2)
(Total 6 marks)

49

Electrolysis can be used to remove unwanted hair from the skin.

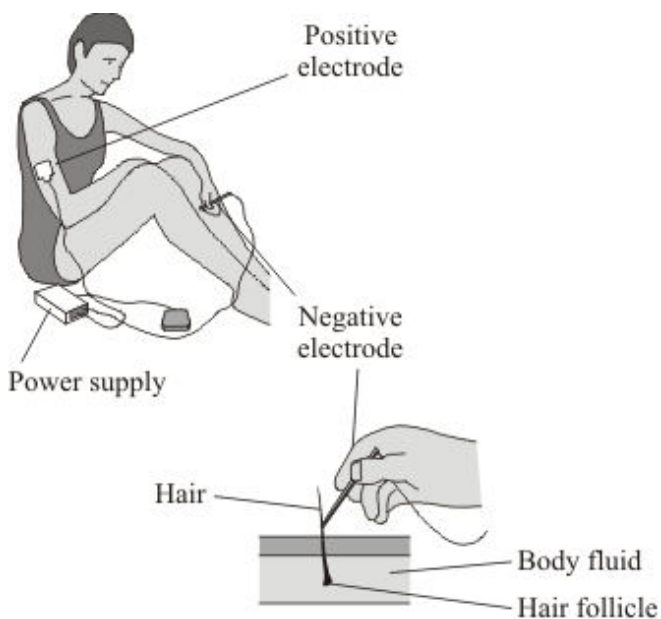

The hair is first coated with a layer of gel containing ions in solution.

The positive electrode is connected by a patch to the skin.

The negative electrode is connected to the hair. Electricity flows through the gel and causes electrolysis of the body fluid around the hair follicle.

- (a) Metal wires conduct electricity to the electrodes.

Explain how metals conduct electricity.

.....

.....

.....

.....

(2)

- (b) Explain why the gel containing ions in solution can conduct electricity.

.....

.....

(1)

- (c) The body fluid is a solution that contains sodium chloride. The electricity causes the electrolysis of a small amount of this solution.

This solution contains hydrogen ions that move to the negative electrode.

- (i) The half equation represents the reaction at the negative electrode.

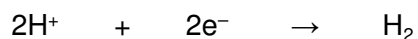

Explain why this reaction is a reduction.

.....

.....

(1)

- (ii) As a result of the electrolysis of sodium chloride solution, an alkali forms which kills the hair follicle.

What is the name of this alkali?

(1)

- (iii) Complete the half equation for the reaction at the positive electrode.

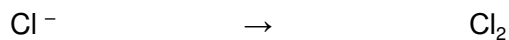

(1)

(Total 6 marks)

50

The diagram shows a circuit that is used in a torch. Electrons flow through this circuit.

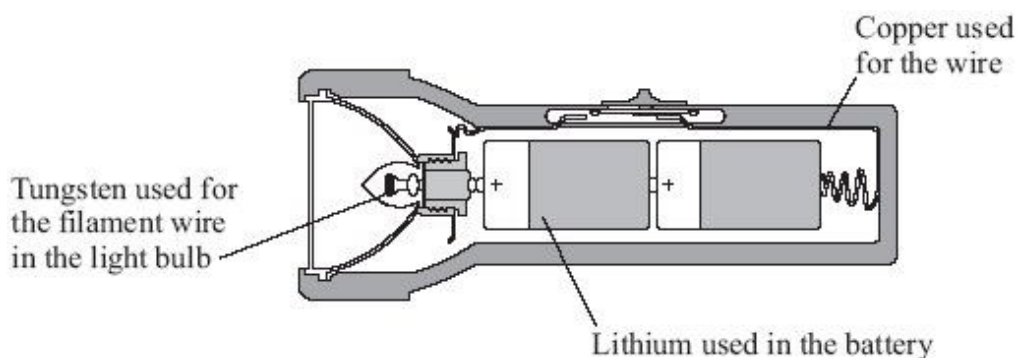

- (a) Why is copper used for the wire?

.....

(1)

- (b) The diagram shows the structure of an atom of lithium.

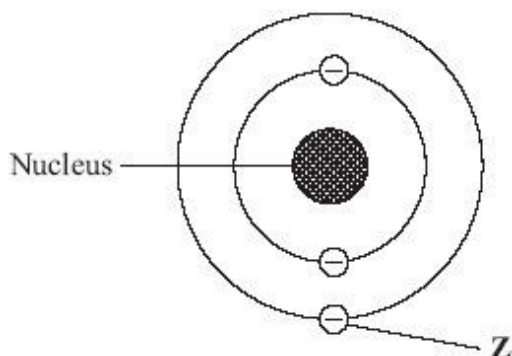

Name the particle labelled Z.

.....

(1)

- (c) The table shows some properties of the metals used in the electrical circuit.

Metal	Melting point in °C	Boiling point in °C	Reaction with oxygen
Copper	1083	2582	Reacts slowly to form a thin oxide layer on surface
Lithium	179	1317	Reacts rapidly to form oxide
Tungsten	3370	5930	Reacts only when very hot to form oxide

- (i) Use information from the table to suggest the order of reactivity for copper, lithium and tungsten.

most reactive

.....

least reactive

(2)

- (ii) The filament wire glows because it gets very hot.

Use information from the table to suggest **one** reason why tungsten is used for the filament wire in the light bulb.

.....

.....

(1)

- (d) The gas used in the light bulb is argon.

Draw a ring around the correct word in the box to complete the sentence.

Argon is used in the light bulb because it is

dense.
solid.
unreactive.

.

(1)

(Total 6 marks)

51

The demand for iron and steel is high.

- (a) Iron that is extracted from its oxide by carbon reduction in a blast furnace is called cast iron. Cast iron contains about 4% carbon. This carbon makes cast iron very brittle.

Carbon steels can be made by the following processes.

- Blowing oxygen into molten cast iron to remove most of the carbon.
- Adding a calculated amount of carbon.

Sometimes different metals may also be added to the molten carbon steels.

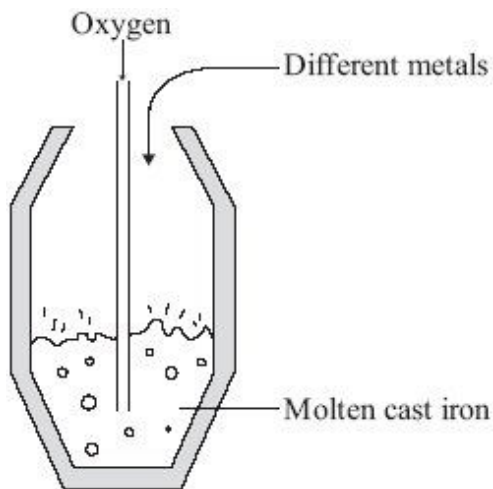

- (i) Suggest how blowing oxygen into molten cast iron removes most of the carbon.

.....
.....
.....
.....

(2)

- (ii) Why are different metals sometimes added to molten carbon steels?

.....
.....

(1)

- (b) The percentage of iron and steel recycled in the UK has been increasing.

Year	%iron and steel recycled
1998	25
2000	35
2002	42
2004	46
2006	57

The UK government has set targets for the percentage of iron and steel to be recycled. In 2006 the target was exceeded.

Suggest **two** reasons why the UK government wants to encourage recycling of iron and steel.

1

.....

2

.....

(2)
(Total 5 marks)

52

Perfumes contain a mixture of chemicals.



The main ingredients of perfumes are a solvent and a mixture of fragrances.

- (a) A sample of the solvent used in one perfume contained 0.60 g of carbon, 0.15 g of hydrogen and 0.40 g of oxygen.

Relative atomic masses: H = 1; C = 12; O = 16.

Calculate the empirical (simplest) formula of the solvent.

You must show all of your working to gain full marks for this question.

.....

.....

.....

.....

.....

.....

.....

.....

.....

.....

.....

(4)

- (b) Solvent molecules evaporate easily.

Explain why substances made of simple molecules evaporate easily.

.....

.....

.....

.....

.....

(2)

- (c) Most companies claim that their perfumes have been tested on skin. A study was made of the tests they used. The study found that each company used different tests.

The perfumes were tested in the companies' own laboratories and **not** by independent scientists.

Some companies did not give any information about the tests that they had used.

- (i) Suggest why companies test their perfumes on skin.

.....
.....
.....

(1)

- (ii) Did the study show that the tests made by the different companies were valid and reliable?

Explain your answer.

.....
.....
.....
.....
.....

(2)

(Total 9 marks)

53

Copper metal is used for electric wires.

An alloy of copper, called brass, is used for pins and terminals of electric plugs.

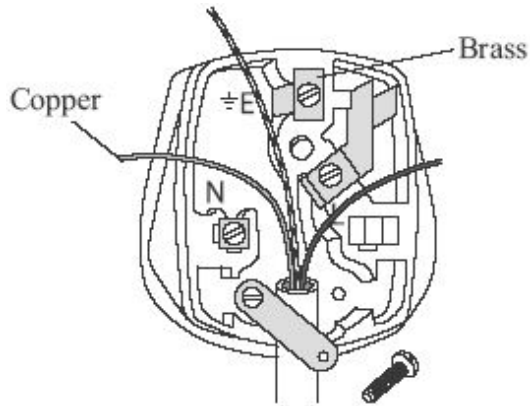

(a) Copper metal is relatively soft and flexible.

Give another reason why copper is used for electric wires.

.....
.....

(1)

(b) Brass is an *alloy*.

What is an *alloy*?

.....
.....

(1)

- (c) Open-cast mining of copper ore makes a very large hole.



- (i) Suggest **one** environmental problem that is caused by open-cast mining of copper ore.

.....

(1)

- (ii) Some copper ores contain copper sulfide, CuS.

Copper sulfide is heated in air to produce copper and sulfur dioxide.

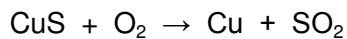

Suggest **one** environmental problem caused by heating copper sulfide in air.

.....

(1)

- (d) The amount of copper-rich ores is estimated to last only a few more years. New houses need several kilometres of copper wire.

- (i) Explain why the need to use so much copper will cause a problem in the future.

.....

(1)

(ii) Suggest **two** ways in which society could overcome this problem.

1

.....

2

.....

(2)
(Total 7 marks)

54

Aluminium has many uses because of its low density, good electrical conductivity, flexibility and resistance to corrosion.

The main steps in the extraction of aluminium are shown in the flow chart.

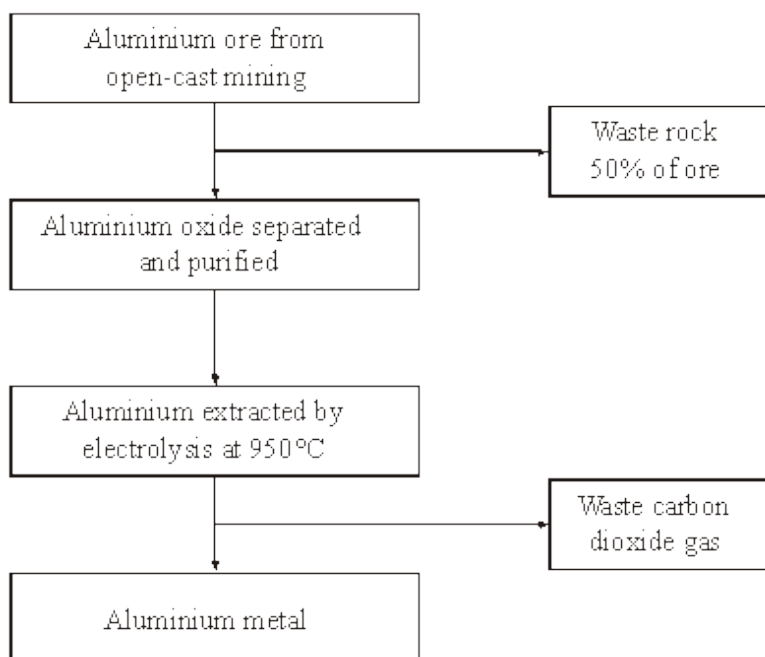

(a) Use the information in the flow chart to suggest the benefits of recycling aluminium.

.....

.....

.....

.....

.....

.....

(3)

- (b) Pure aluminium is rarely used for the construction of large objects. Small amounts of other metals are usually mixed with aluminium.

Explain why.

.....

.....

.....

.....

(2)
(Total 5 marks)